



Phastite[®] Tube Connectors

Catalog 4235-PH

aerospace
climate control
electromechanical
filtration
fluid & gas handling
hydraulics
pneumatics
process control
sealing & shielding



ENGINEERING YOUR SUCCESS.

Phastite® Tube Connectors

Contents

Page 3	Phastite® : The Concept
Page 4-5	Phastite® : The Benefits
Page 6	Value Proposition
Page 7	Phastite® Connectors: Sealing
Page 8-9	Phastite®: The Assembly Process
Page 10-11	Phastite® testing
Page 12-13	Visual Index
Page 14	Phastite® Unions Straight Connectors (Permanent)
Page 15	Phastite® Unions Elbow Connectors (Permanent)
Page 16	Phastite® Unions Tees Connectors (Permanent)
Page 17	Phastite® Unions Cross Connectors (Permanent)
Page 18	Phastite® Unions Straight Drop Size Connectors (Permanent)
Page 19	Phastite® Tube Reducer
Page 20	Phastite® Unions Straight Connectors (Termination to Permanent)
Page 21	Phastite® Male Straight Connectors (Termination)
Page 22	Phastite® Female Straight Connectors (Termination)
Page 23	Phastite® Male Straight Connectors BSPT (Termination)
Page 24	Phastite® Female Straight Connectors BSPT (Termination)
Page 25	Phastite® Male Straight Connectors BSPP (Termination)
Page 26	Phastite® Female Straight Connectors BSPP (Termination)
Page 27	Phastite® Male Straight Connectors (Medium Pressure)
Page 28-30	Phastool
Page 31	Tool Jaw inserts
Page 32	Tube Markers
Page 33	Pumps
Page 34	How to Order
Page 35-37	Tube Selection and Pressure Ratings
Page 38	Heat Code Traceability

Phastite® : The Concept

A Ferrule-less, Push-Fit Connector.

Phastite® is a breakthrough in tube connection systems; its innovative design concept combines quick installation with a simple assembly process achieving a tube connector that can be used in applications up to 20,000 psi/ 1380 bar (see pages 19, 20 & 21).

The product is manufactured from standard materials and requires no special processes to be adopted.

Phastite® makes the perfect replacement for other fitting methods currently being utilised and performance parameters are such that it is suitable for pressure applications up to 20,000 psi/1380 bar (see pages 19, 20 & 21). Specifically, Phastite® is a reliable alternative to high pressure connections and/or welded connectors in these applications.

Design

Phastite® has been specifically designed to meet ever-increasing industry standards and demands with regards to tube connectors and pressure containment. The latest CAE and FEA techniques have been employed to optimise the design of the connectors and assembly tooling.

Manufacturing

State of the art machining centres and over 40 years of connector manufacturing has been utilised for accurate and consistent manufacturing of Phastite® connectors. Manufactured in Parker's facilities where strict quality controls are employed to ensure reliability and consistency.

Testing

Phastite® meets all the relevant performance and functional requirements of industry standards, including pressure containment to a safety factor of a minimum of 4:1, proven by actual tubing burst tests. Throughout the development of Phastite®, product performance and integrity were paramount. A rigorous testing program including Thermal Cycling, Shock, Vibration, Helium Leak, Gas Tight and Hydrostatic testing has been completed.

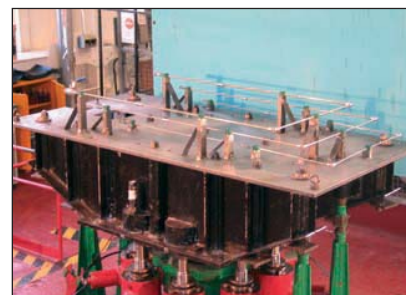
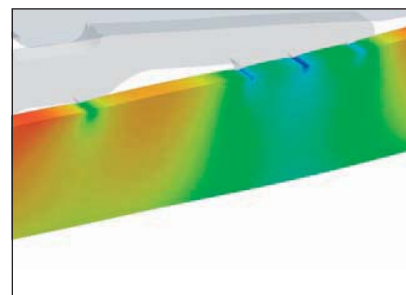

WARNING

FAILURE, IMPROPER SELECTION OR IMPROPER USE OF THE PRODUCTS AND/OR SYSTEMS DESCRIBED HEREIN OR RELATED ITEMS CAN CAUSE DEATH, PERSONAL INJURY AND PROPERTY DAMAGE.

This document and other information from Parker Hannifin Corporation, its subsidiaries and authorized distributors provide product and/or system options for further investigation by users having technical expertise. It is important that you analyze all aspects of your application and review the information concerning the product or system in the current product catalog. Due to the variety of operating conditions and applications for these products or systems, the user, through its own analysis and testing, is solely responsible for making the final selection of the products and systems and assuring that all performance, safety and warning requirements of the application are met.

The products described herein, including without limitation, product features, specifications, designs, availability and pricing, are subject to change by Parker Hannifin Corporation and its subsidiaries at any time without notice.

Offer of sale

The items described in this document are hereby offered for sale by Parker Hannifin Corporation, its subsidiaries or its authorized distributors. This offer and its acceptance are governed by the provisions stated in the "Offer of Sale" located in Catalog 4190-U Needle Valves (U Series).

Phastite® Tube Connectors

Phastite® : The Benefits

Safety

- Supplied pre-assembled, no loose parts thus eliminating potential assembly errors.
- No additional operations using equipment that could lead to injury (such as hand held angle grinders) are required.
- Permanent assembly is tamper proof.
- Permanent leak free connections without the need for threaded components, thus removing potential loosening problems due to excess movement.
- No Hot Work! Fire or explosion risks are eliminated along with any potential fume inhalation.
- No disposal of hazardous materials used in any Hot Work activities.
- No brittleness or corrosion implications (caused by welding heat for example).

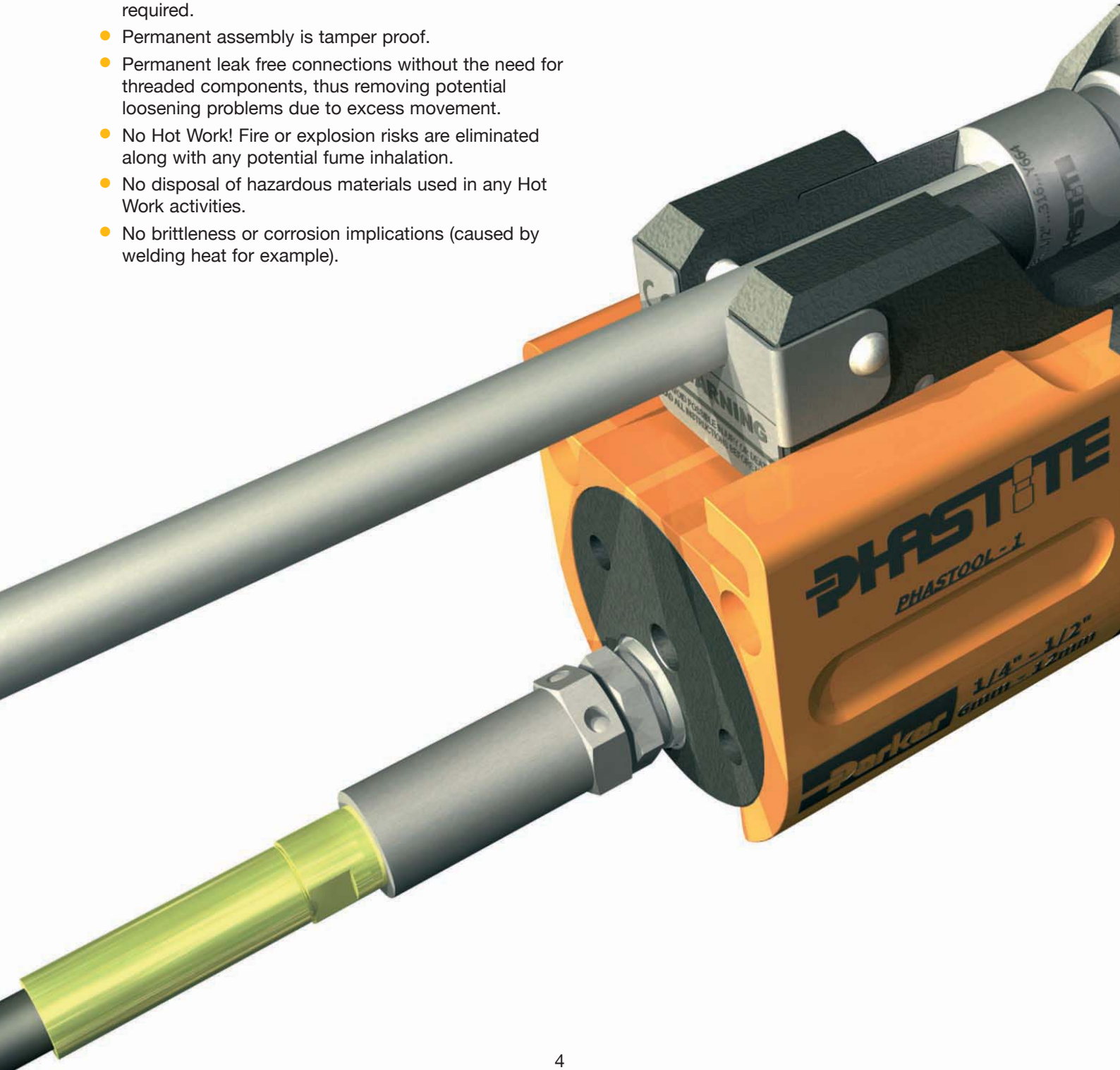
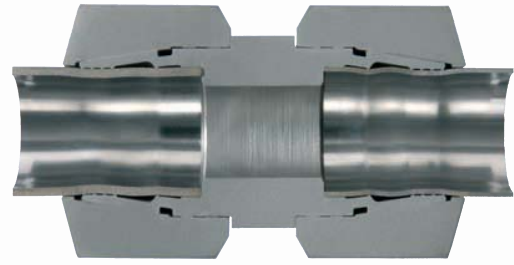

Phastite® Tube Connectors



Installation

- Simple installation process removes the need for skilled labour. The Phastite® tool assures connections are right first time, every time.
- Assembled in seconds, reducing assembly and project lead times.
- Suitable for a wide variety of markets and applications.
- Tolerant of tubing variation and defects, reducing work and re-testing.
- Easy in situ assembly, even close up against panels/bulkheads.

Cost of Ownership

- No inspection requirements such as X-Ray or Dye penetrant testing during installation.
- No re-work, just fit and forget.
- No consumables such as welding rods, gases or cutting oil.
- No Hot Work permits required.
- Potential tube cost & weight savings (Phastite® is suitable for use on a wide range of wall thicknesses – including thin wall tube for gas applications).

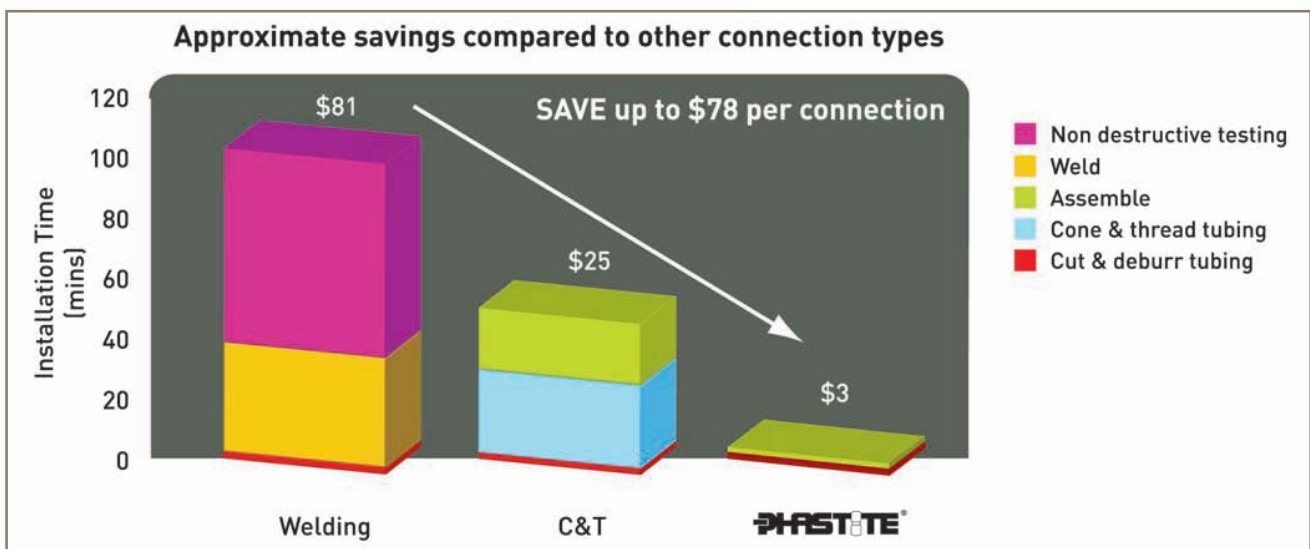

Phastite® Tube Connectors

Value Proposition

Reduced Installation Costs

Phastite® offers an extremely quick, easy and simple way of connecting tubing. When considering how much time it takes to either weld or cone and thread tubing, Phastite® delivers a large reduction in total cost.

Simple assembly process

The Phastite® tooling, together with the connector's unique design ensures a leak free connection first time, every time. This enables assembly time to be reduced from hours down to seconds.

No need to re-make or re-test

Phastite® delivers a leak free connection with no need for costly and time consuming re-making or re-testing.

No welding required

With Phastite® a permanent connection can be made in seconds without the need for certified labour or costly testing requirements.

Reduced tubing costs

Phastite® is used with standard tubing material. Controlled chemical composition or special tubing tolerances are not needed.

No special requirements

Standard ASTM A-269 or equivalent tubing is all that is needed for Phastite®.

Weight reduction

The need for extra wall thickness to allow threading is eliminated, meaning that weight as well as the tubing costs are reduced.

Increased Safety

Phastite's simple assembly process dramatically reduces the number of operations needed to assemble a leak free joint. Simply insert the tubing into the pre-assembled connector. The Phastite® tooling delivers a leak free connection.

No loose parts

Phastite® connectors are supplied pre-assembled, no loose parts and no disassembling needed by the installer. This eliminates errors when assembling, as there are no parts to lose or to incorrectly assemble.

Simple make-up

Consistent make-up to a pre-determined stop face on the body. No measuring, simply insert the tube into the connector and let the tool do the rest. This reduces the possibility of any incorrect make-up.

Vibration tolerant

Phastite® provides a permanent leak free connection. There are no threaded components, removing potential loosening problems in vibration applications.

No need for hot work

Phastite® provides a leak free connection suitable for replacing welded systems, removing the associated risks with welding.

Approval



Phastite® Tube Connectors

Phastite® Permanent Connectors



Phastite® permanent connectors use patented sealing technology to provide a unique permanent joint onto standard ASTM A269 tubing. The robust design ensure leak free performance in the most demanding of applications, and yet can be assembled in seconds with no manual effort.

Phastite's unique sealing ability allows the same product to be used on the extremes of tube wall thickness, ranging from thin wall sections as low as 0.5mm (0.020") for light weight low pressure applications, to 4.8mm (0.188") for high pressure thick wall systems.

Sealing

The excellent sealing and holding properties of Phastite® is achieved by its unique design. It not only secures metal to metal sealing points onto the tubing from its unique formed peaks within the bore of the connector body but allows the tubing to expand into the pre-machined cavities giving additional holding properties.

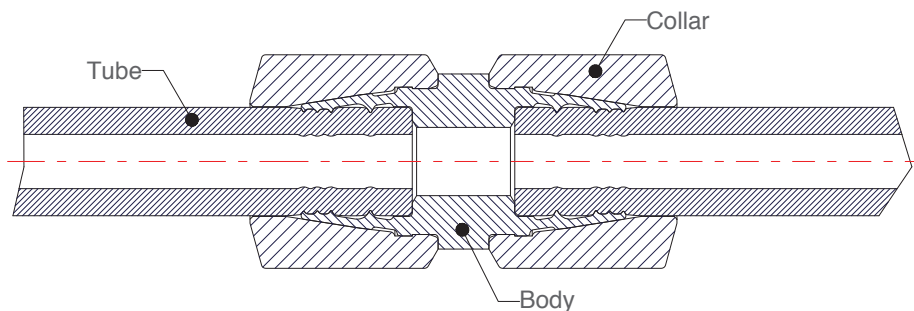

Phastite® Termination Connectors



Phastite® termination connectors use the same patented sealing technology as the permanent connector to provide a unique joint onto standard ASTM A269 tubing, with the additional ability of being able to 'break' and 'remake' the joint.

The design maintains the unique abilities of the permanent connector but provides an additional joint which provides the ability for installations to be maintained.

Phastite® Tube Connectors

Phastite® Permanent Connectors - The Assembly Process

The Phastite® fitting is supplied complete with the collars pre-assembled to the body, thus removing the risk of losing or incorrectly assembling components.



The tubes are simply inserted into the Phastite® connector, adequate tube insertion is assured by using the Phastite® tube marker.

Simple assembly to a metal to metal stop face ensures correct assembly every time, without counting turns or monitoring torque levels.



A series of formed ridges makes contact with the tubing surface uniformly to create both a multiple seal and a secure mechanical grip.



Phastite® Tube Connectors

Phastite® Termination Connectors - The Assembly Process

The Phastite® fitting is supplied complete with the collars pre-assembled to the body, retaining the swivel nut, thus removing the risk of losing or incorrectly assembling components.



The tubes are simply inserted into the Phastite® connector, adequate tube insertion is assured by using the Phastite® tube marker.



Simple assembly to a metal to metal stop face ensures correct assembly every time, without counting turns or monitoring torque levels.

A series of formed ridges makes contact with the tubing surface uniformly to create both a multiple seal and a secure mechanical grip.

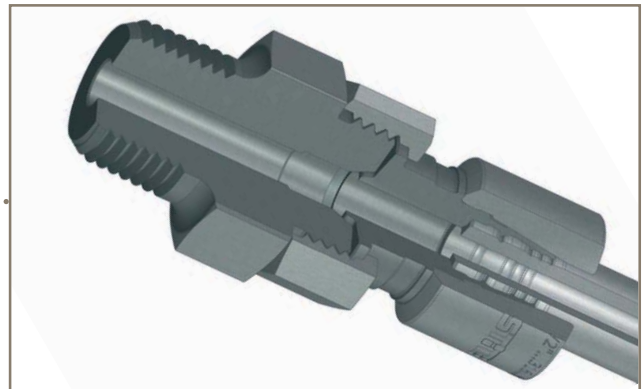

A mating conical arrangement provides leak tight sealing at the breakable joint, while correct assembly is ensured by a metal to metal stop face, without counting turns or monitoring torque levels.

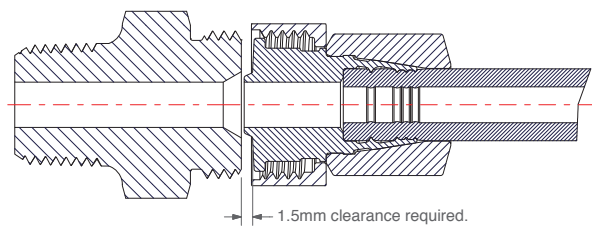
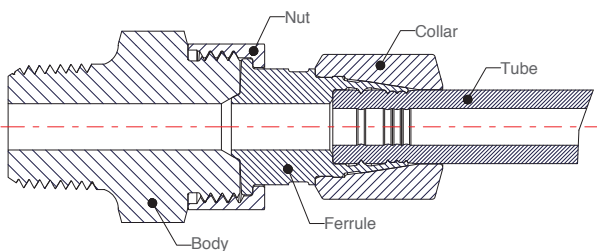

The ability to 'break' and 'remake' the joint is dramatically enhanced by the virtual zero clearance of the design. Allowing the joint to be completely disconnected and removed without large pull out being required.

Phastite® Tube Connectors

During the development of Phastite®, a very rigorous testing programme was undertaken. Phastite® met or exceeded all requirements including, but not limited to, the following tests. Various connector types were tested: including shapes, terminations and straights. Along side internal testing in our state of the art facility, additional samples were sub-contracted for external testing. Various tests have also been externally validated by Lloyds and the TUV. The following results provide a pleasing outcome with regards to Phastite® operating parameters.

Pressure containment

Hydrostatic testing was carried out for all tube sizes on the thickest and thinnest wall tubing as laid out in the tube selection guide on page 35. A large quantity of these tests have been carried out internally and externally and witnessed by various 3rd parties and customers. Phastite® product has been subjected to pressure of 1.5 times the tubes maximum working pressure to ensure adequate sealing and tube grip.

Gas testing

Pressure testing using nitrogen and / or helium gas at 100 bar (1500 psi) to ensure gas tight sealing is achieved followed by a high pressure gas test at full cold working pressure. These tests have been carried out fully in accordance to ISO 19879 and externally witnessed.

Helium vacuum test

A vacuum is achieved by removing the contents of the contained volume by means of a vacuum pump. The pump maintains the required level of vacuum within the test piece by operating continually. Helium gas is subjected to the connector joints of the test piece assembly and using a mass spectrometer the level of leakage is determined. Phastite® exhibits leak rates of less than 1×10^{-9} cc Atm/sec.

Vibration

Vibration tests have been carried out fully in accordance to ISO 19879 and BS 4368 at 20 million cycles at between 23 and 47Hz. The test specimen is pressurised with Helium / Nitrogen at a pre-determined pressure. No pressure loss or visible leakage is acceptable throughout the test.

Combined pulsation and vibration

Combined Pulsation and Vibration tests have been carried out fully in accordance to ISO 19879 and BS

4368. The test specimen is pressurised with hydraulic fluid at a pre-determined pressure. The test specimen is subjected to both vibration and pulsation forces at once to simulate an extreme service condition. No pressure loss or visible leakage was acceptable throughout the test.

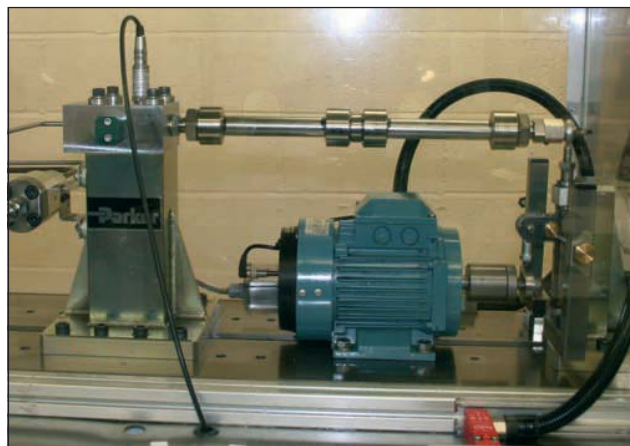

Vibration test

Hydrostatic burst test

This test internally pressurises the complete Phastite® tube assembly until destruction. In all cases the tube has proven to be the weakest component within the assembly. The tests ensured that tube burst was achieved on all sizes without any movement of the Phastite® fitting and a 4:1 design factor is applied to give the relevant safe working pressure.

Thermo cycling

Phastite® tube assemblies have been subjected to thermo cycling from -50°C to +175°C (-58°F to 347°F), whilst pressurised with helium gas. No pressure loss or visible leakage was acceptable throughout the test.

In addition to the above testing more specific testing has been carried out for specific applications.

Deflection test

Phastite® was tested to prove its holding power by securing connectors at each end of two half-metre



Tube compression

Phastite® Tube Connectors

lengths of tubing joined by a Phastite® connector in the middle of the assembly. A load was applied to deflect the middle connector by a distance of 60mm (2.36”) whilst pressurised at 2610 psi (180 bar) with no leakage experienced. This meet the customers requirements however a more stringent test was also completed, deflecting the assembly by 300mm. Pressure was increased until tube burst was achieved. Once again proving the ability of the Phastite® product.

Shock test

One of the world’s leading defence technology and security companies have been commissioned to perform shock tests on Phastite® fittings. This test program consisted of a variety of tests based on shocks designed to simulate explosive forces. All tests had a positive outcome and ensured full compliance with the international standard governing shock testing. No leakage was observed during the tests or during the 300bar (4351psi) pressure test of 15 minutes duration. The pipe work was permanently distorted after the tests but Phastite® held firm.

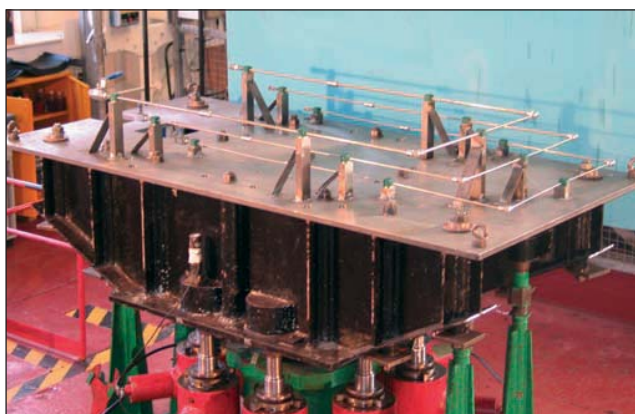

Shock test

External Pressure test

In addition to Phastite’s ability to withstand internal pressures, Phastite® has been externally pressure tested to ensure sealability in external pressure

Typical raw material specifications

Basic connector material	Bar Stock	Common Tubing specification
Stainless Steel (Type 316)	ASME-SA-479 Type 316-SS	ASTM-A-269
	BS970 316-S31	ASTM-A-249
	DIN 4401	ASTM-A-213
	ASTM A276 Type 316	



Rotation test

applications. In all cases external pressure was applied with helium or nitrogen gas. At no point did leakage occur and in a number of cases the external pressure was adequate to collapse the tool without losing the Phastite® seal.

Fire test

The Phastite® product has been fully tested in accordance to BS.6755 pt 2. In this test the assembly is subjected to a fire scenario with temperatures in excess of 750°C (1382°F) for over 30 minutes. The test pieces are pressurised throughout the test period and are constantly examined for leakage / water loss. Phastite® past these test requirements with no visible leakage or water loss.

Pull test

The Phastite® product has been subjected to a pull test where a Phastite® fitting is assembled between two tube lengths. These tube lengths are then mechanically pulled apart until failure, thus ensuring the resistive strength of Phastite®.

Phastite® Tube Connectors

Visual Index

PS
Permanent Union
Equal Straight
page 14

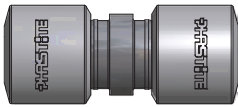

PS
Permanent Union Drop
Size Straight
page 14

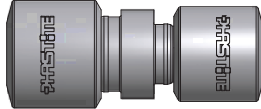

PE
Permanent Union
Equal Elbow
page 15



PT
Permanent Union
Equal Tee
page 16

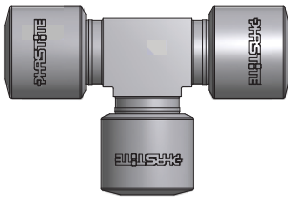

PC
Permanent Union
Equal Cross
page 17

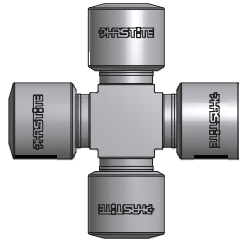

PS
Permanent Union
Drop Size
page 18

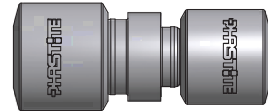

TR
Tube
Reducer
page 19

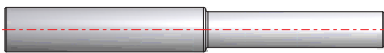

TPS
Termination to Permanent
Union Equal Straight
page 20

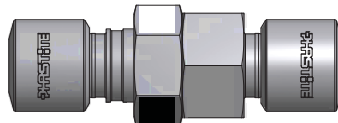

TPS
Permanent Union Equal
Tee with Drop Size
Termination Branch
page 20

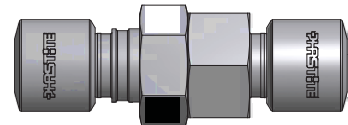

TMS-N
Termination Male Straight -
NPT
page 21

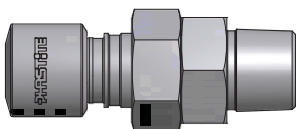

TFS-N
Termination Female Straight -
NPT
page 22

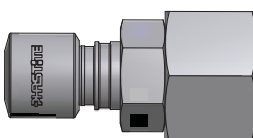

TMS-K
Termination Male Straight -
BSPT
page 23

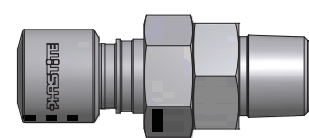

Please note: Phastite® is also available to suit 20,000 psi pressure cone and thread tubing. Please contact Parker for more information.

Phastite® Tube Connectors

TFS-K
Termination Female Straight -
BSPT
page 24

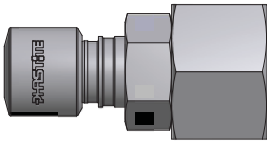

TMS-R
Termination Male Straight -
BSPP
page 25

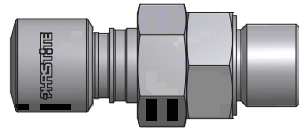

TFS-R
Termination Female Straight -
BSPP
page 26

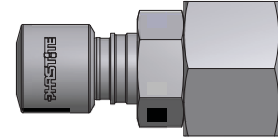

TXAS
Termination Male Straight -
20,000 PSI Medium Pressure
page 27

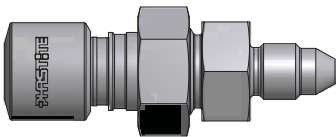

Phastool
Hand Held
page 28



Phastool
Bench Mounted
page 29



Phastool
Bench Tool
page 30



Tool Jaw
Inserts
page 31



Tube
Marker
page 32



Pumps
page 33



Please note: Phastite® is also available to suit 20,000 psi pressure cone and thread tubing. Please contact Parker for more information.

Phastite® Tube Connectors

PS Permanent Union Equal Straight

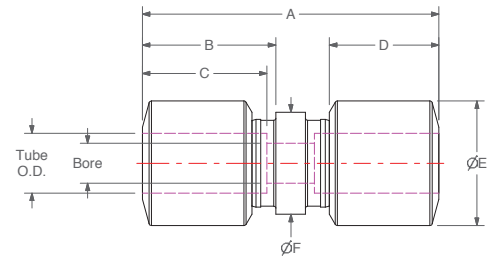
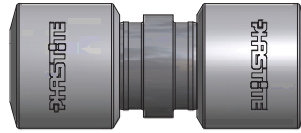

Imperial

Part No.	Tube O.D.	A	B	C	D	E	F	Bore
PH-4-PS	1/4"	54.1 (2.13")	23.7 (0.93")	20.9 (0.82")	19.0 (0.75")	17.0 (0.67")	12.7 (0.50")	4.0 (0.16")
PH-6-PS	3/8"	58.1 (2.29")	25.7 (1.01")	22.9 (0.90")	21.0 (0.83")	22.0 (0.87")	17.0 (0.67")	6.0 (0.24")
PH-8-PS	1/2"	59.3 (2.33")	26.7 (1.05")	23.6 (0.93")	22.0 (0.87")	25.0 (0.98")	20.5 (0.81")	8.0 (0.31")
PH-10-PS	5/8"	69.8 (2.75")	29.7 (1.17")	25.9 (1.02")	25.0 (0.98")	32.0 (1.26")	25.0 (0.98")	12.0 (0.47")
PH-12-PS	3/4"	81.4 (3.21")	35.6 (1.40")	31.2 (1.23")	29.5 (1.16")	36.0 (1.42")	29.5 (1.16")	14.0 (0.55")
PH-14-PS	7/8"	85.6 (3.37")	37.6 (1.48")	32.4 (1.28")	31.0 (1.22")	43.0 (1.69")	34.5 (1.36")	16.0 (0.63")
PH-16-PS	1"	93.5 (3.68")	40.3 (1.59")	34.8 (1.37")	33.5 (1.32")	50.0 (1.97")	38.0 (1.50")	18.0 (0.71")

Variants suitable for use on Medium Pressure Tube i.e. 9/16" are available upon request.

PS Permanent Union Equal Straight

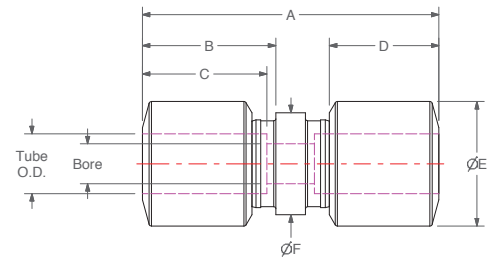
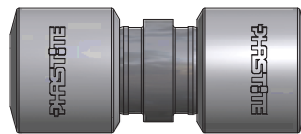

Metric

Part No.	Tube O.D.	A	B	C	D	E	F	Bore
PH-M6-PS	6mm	54.1 (2.13")	23.7 (0.93")	20.9 (0.82")	19.0 (0.75")	17.0 (0.67")	12.7 (0.50")	4.0 (0.16")
PH-M8-PS	8mm	56.1 (2.21")	24.7 (0.97")	21.9 (0.86")	20.0 (0.79")	19.0 (0.75")	15.4 (0.61")	5.0 (0.20")
PH-M10-PS	10mm	58.1 (2.29")	25.7 (1.01")	22.9 (0.90")	21.0 (0.83")	22.0 (0.87")	17.0 (0.67")	6.0 (0.24")
PH-M12-PS	12mm	59.5 (2.34")	26.7 (1.05")	23.1 (0.91")	22.0 (0.87")	25.0 (0.98")	20.5 (0.81")	8.0 (0.31")
PH-M14-PS	14mm	61.2 (2.41")	26.7 (1.05")	23.3 (0.92")	22.0 (0.87")	28.0 (1.10")	22.5 (0.89")	10.0 (0.39")
PH-M16-PS	16mm	69.5 (2.74")	29.7 (1.17")	25.9 (1.02")	25.0 (0.98")	32.0 (1.26")	25.0 (0.98")	12.0 (0.47")
PH-M18-PS	18mm	84.4 (3.32")	35.6 (1.40")	31.6 (1.24")	29.5 (1.16")	36.0 (1.42")	29.5 (1.16")	14.0 (0.55")
PH-M20-PS	20mm	82.0 (3.23")	35.6 (1.40")	31.0 (1.22")	29.5 (1.16")	36.0 (1.42")	30.5 (1.20")	14.0 (0.55")
PH-M22-PS	22mm	87.2 (3.43")	37.6 (1.48")	32.7 (1.29")	31.0 (1.22")	43.0 (1.69")	34.5 (1.36")	16.0 (0.63")
PH-M25-PS	25mm	94.1 (3.71")	40.3 (1.59")	34.8 (1.37")	33.5 (1.32")	50.0 (1.97")	38.0 (1.50")	18.0 (0.71")

Dimensions for reference only, subject to change.

Phastite® Tube Connectors

PE Permanent Union Equal Elbow

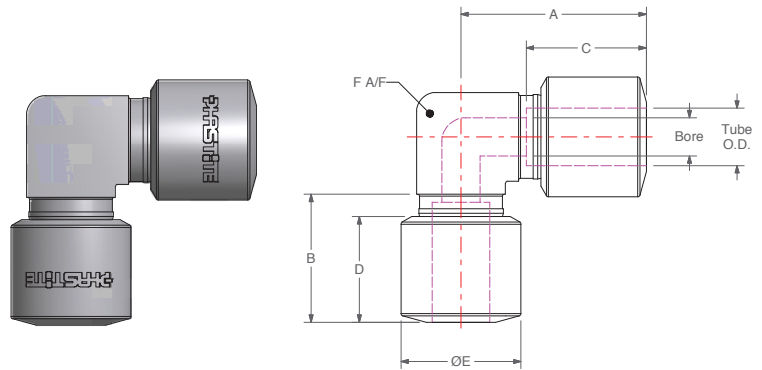

Imperial

Part No.	Tube O.D.	A	B	C	D	E	F	Bore
PH-4-PE	1/4"	37.2 (1.47")	23.7 (0.93")	20.9 (0.82")	19.0 (0.75")	17.0 (0.67")	14.5 (0.57")	4.0 (0.16")
PH-6-PE	3/8"	39.2 (1.54")	25.7 (1.01")	22.9 (0.90")	21.0 (0.83")	22.0 (0.87")	14.5 (0.57")	6.0 (0.24")
PH-8-PE	1/2"	38.6 (1.52")	26.7 (1.05")	23.6 (0.93")	22.0 (0.87")	25.0 (0.98")	18.5 (0.73")	8.0 (0.31")
PH-10-PE	5/8"	45.9 (1.81")	29.7 (1.17")	25.9 (1.02")	25.0 (0.98")	32.0 (1.26")	22.5 (0.89")	12.0 (0.47")
PH-12-PE	3/4"	55.1 (2.17")	35.6 (1.40")	31.2 (1.23")	29.5 (1.16")	36.0 (1.42")	28.5 (1.12")	14.0 (0.55")
PH-14-PE	7/8"	59.4 (2.34")	37.6 (1.48")	32.4 (1.28")	31.0 (1.22")	43.0 (1.69")	33.5 (1.32")	16.0 (0.63")
PH-16-PE	1"	65.6 (2.58")	40.3 (1.59")	34.8 (1.37")	33.5 (1.32")	50.0 (1.97")	38.5 (1.52")	18.0 (0.71")

Variants suitable for use on Medium Pressure Tube i.e. 9/16" are available upon request.

PE Permanent Union Equal Elbow

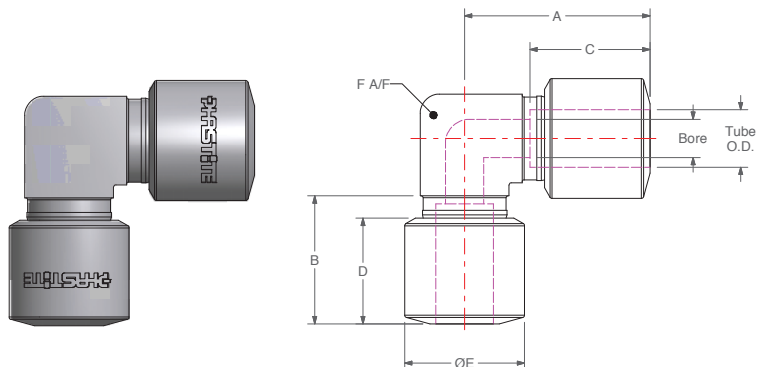

Metric

Part No.	Tube O.D.	A	B	C	D	E	F	Bore
PH-M6-PE	6mm	37.2 (1.47")	23.7 (0.93")	20.9 (0.82")	19.0 (0.75")	17.0 (0.67")	14.5 (0.57")	4.0 (0.16")
PH-M8-PE	8mm	38.2 (1.51")	24.7 (0.97")	21.9 (0.86")	20.0 (0.79")	19.0 (0.75")	14.5 (0.57")	5.0 (0.20")
PH-M10-PE	10mm	39.2 (1.54")	25.7 (1.01")	22.9 (0.90")	21.0 (0.83")	22.0 (0.87")	18.5 (0.73")	6.0 (0.24")
PH-M12-PE	12mm	38.7 (1.53")	26.7 (1.05")	23.1 (0.91")	22.0 (0.87")	25.0 (0.98")	18.5 (0.73")	8.0 (0.31")
PH-M14-PE	14mm	42.1 (1.66")	26.7 (1.05")	23.3 (0.92")	22.0 (0.87")	28.0 (1.10")	20.5 (0.81")	10.0 (0.39")
PH-M16-PE	16mm	45.7 (1.80")	29.7 (1.17")	25.9 (1.02")	25.0 (0.98")	32.0 (1.26")	22.5 (0.89")	12.0 (0.47")
PH-M18-PE	18mm	57.2 (2.25")	35.6 (1.40")	31.6 (1.24")	29.5 (1.16")	36.0 (1.42")	28.5 (1.12")	14.0 (0.55")
PH-M20-PE	20mm	54.0 (2.13")	35.6 (1.40")	31.0 (1.22")	29.5 (1.16")	36.0 (1.42")	28.5 (1.12")	14.0 (0.55")
PH-M22-PE	22mm	60.6 (2.39")	37.6 (1.48")	32.7 (1.29")	31.0 (1.22")	43.0 (1.69")	33.5 (1.32")	16.0 (0.63")
PH-M25-PE	25mm	66.0 (2.60")	40.3 (1.59")	34.8 (1.37")	33.5 (1.32")	50.0 (1.97")	38.5 (1.52")	18.0 (0.71")

Dimensions for reference only, subject to change.

Phastite® Tube Connectors

PT Permanent Union Equal Tee

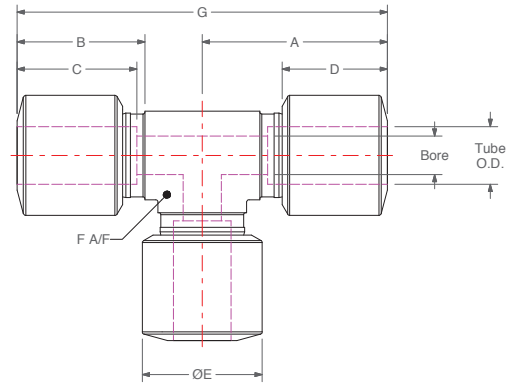
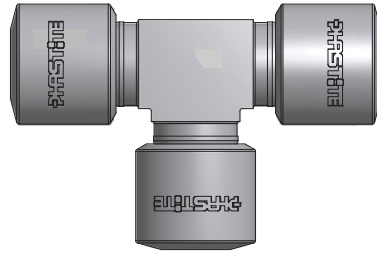

Imperial

Part No.	Tube O.D.	A	B	C	D	E	F	G	Bore
PH-4-PT	1/4"	37.2 (1.47")	23.7 (0.93")	20.9 (0.82")	19.0 (0.75")	17.0 (0.67")	14.5 (0.57")	74.5 (2.93")	4.0 (0.16")
PH-6-PT	3/8"	39.2 (1.54")	25.7 (1.01")	22.9 (0.90")	21.0 (0.83")	22.0 (0.87")	14.5 (0.57")	78.5 (3.09")	6.0 (0.24")
PH-8-PT	1/2"	38.6 (1.52")	26.7 (1.05")	23.6 (0.93")	22.0 (0.87")	25.0 (0.98")	18.5 (0.73")	77.3 (3.04")	8.0 (0.31")
PH-10-PT	5/8"	45.9 (1.81")	29.7 (1.17")	25.9 (1.02")	25.0 (0.98")	32.0 (1.26")	22.5 (0.89")	91.8 (3.61")	12.0 (0.47")
PH-12-PT	3/4"	55.1 (2.17")	35.6 (1.40")	31.2 (1.23")	29.5 (1.16")	36.0 (1.42")	28.5 (1.12")	110.2 (4.34")	14.0 (0.55")
PH-14-PT	7/8"	59.4 (2.34")	37.6 (1.48")	32.4 (1.28")	31.0 (1.22")	43.0 (1.69")	33.5 (1.32")	118.8 (4.68")	16.0 (0.63")
PH-16-PT	1"	65.6 (2.58")	40.3 (1.59")	34.8 (1.37")	33.5 (1.32")	50.0 (1.97")	38.5 (1.52")	131.3 (5.17")	18.0 (0.71")

Variants suitable for use on Medium Pressure Tube i.e. 9/16" are available upon request.

PT Permanent Union Equal Tee

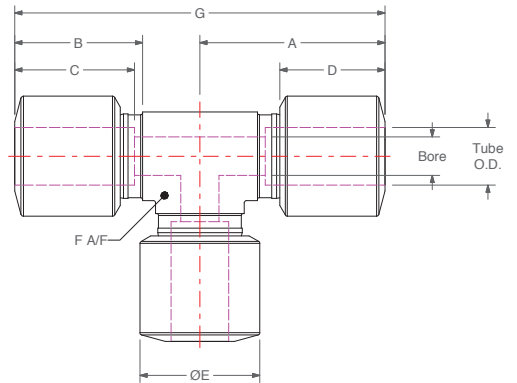
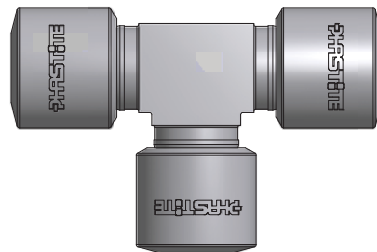

Metric

Part No.	Tube O.D.	A	B	C	D	E	F	G	Bore
PH-M6-PT	6mm	37.2 (1.47")	23.7 (0.93")	20.9 (0.82")	19.0 (0.75")	17.0 (0.67")	14.5 (0.57")	74.5 (2.93")	4.0 (0.16")
PH-M8-PT	8mm	38.2 (1.51")	24.7 (0.97")	21.9 (0.86")	20.0 (0.79")	19.0 (0.75")	14.5 (0.57")	76.5 (3.01")	5.0 (0.20")
PH-M10-PT	10mm	39.2 (1.54")	25.7 (1.01")	22.9 (0.90")	21.0 (0.83")	22.0 (0.87")	18.5 (0.73")	78.5 (3.09")	6.0 (0.24")
PH-M12-PT	12mm	38.7 (1.53")	26.7 (1.05")	23.1 (0.91")	22.0 (0.87")	25.0 (0.98")	18.5 (0.73")	77.5 (3.05")	8.0 (0.31")
PH-M14-PT	14mm	42.1 (1.66")	26.7 (1.05")	23.3 (0.92")	22.0 (0.87")	28.0 (1.10")	20.5 (0.81")	84.2 (3.32")	10.0 (0.39")
PH-M16-PT	16mm	45.7 (1.80")	29.7 (1.17")	25.9 (1.02")	25.0 (0.98")	32.0 (1.26")	22.5 (0.89")	91.5 (3.60")	12.0 (0.47")
PH-M18-PT	18mm	57.2 (2.25")	35.6 (1.40")	31.6 (1.24")	29.5 (1.16")	36.0 (1.42")	28.5 (1.12")	114.4 (4.50")	14.0 (0.55")
PH-M20-PT	20mm	54.0 (2.13")	35.6 (1.40")	31.0 (1.22")	29.5 (1.16")	36.0 (1.42")	28.5 (1.12")	108.0 (4.25")	14.0 (0.55")
PH-M22-PT	22mm	60.6 (2.39")	37.6 (1.48")	32.7 (1.29")	31.0 (1.22")	43.0 (1.69")	33.5 (1.32")	121.2 (4.77")	16.0 (0.63")
PH-M25-PT	25mm	66.0 (2.60")	40.3 (1.59")	34.8 (1.37")	33.5 (1.32")	50.0 (1.97")	38.5 (1.52")	131.9 (5.19")	18.0 (0.71")

Dimensions for reference only, subject to change.

Phastite® Tube Connectors

PC Permanent Union Equal Cross

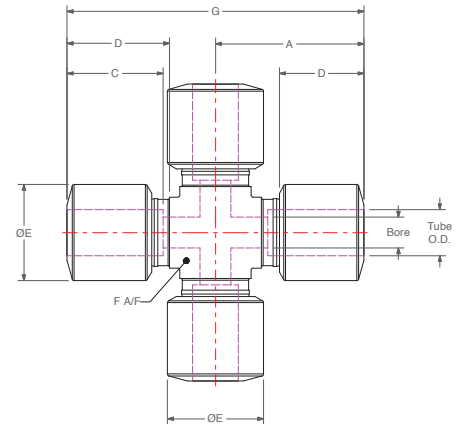

Imperial

Part No.	Tube O.D.	A	B	C	D	E	F	G	Bore
PH-4-PC	1/4"	37.2 (1.47")	23.7 (0.93")	20.9 (0.82")	19.0 (0.75")	17.0 (0.67")	14.5 (0.57")	74.5 (2.93")	4.0 (0.16")
PH-6-PC	3/8"	39.2 (1.54")	25.7 (1.01")	22.9 (0.90")	21.0 (0.83")	22.0 (0.87")	14.5 (0.57")	78.5 (3.09")	6.0 (0.24")
PH-8-PC	1/2"	38.6 (1.52")	26.7 (1.05")	23.6 (0.93")	22.0 (0.87")	25.0 (0.98")	18.5 (0.73")	77.3 (3.04")	8.0 (0.31")
PH-10-PC	5/8"	45.9 (1.81")	29.7 (1.17")	25.9 (1.02")	25.0 (0.98")	32.0 (1.26")	22.5 (0.89")	91.8 (3.61")	12.0 (0.47")
PH-12-PC	3/4"	55.1 (2.17")	35.6 (1.40")	31.2 (1.23")	29.5 (1.16")	36.0 (1.42")	28.5 (1.12")	110.2 (4.34")	14.0 (0.55")
PH-14-PC	7/8"	59.4 (2.34")	37.6 (1.48")	32.4 (1.28")	31.0 (1.22")	43.0 (1.69")	33.5 (1.32")	118.8 (4.68")	16.0 (0.63")
PH-16-PC	1"	65.6 (2.58")	40.3 (1.59")	34.8 (1.37")	33.5 (1.32")	50.0 (1.97")	38.5 (1.52")	131.3 (5.17")	18.0 (0.71")

Variants suitable for use on Medium Pressure Tube i.e. 9/16" are available upon request.

PC Permanent Union Equal Cross

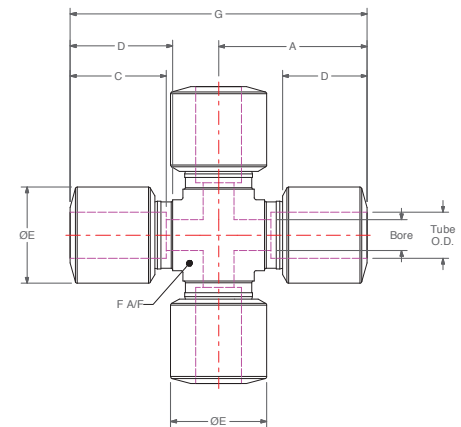
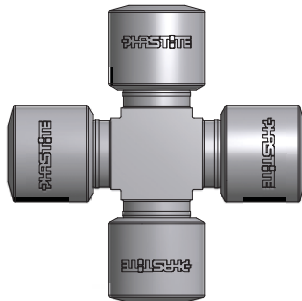

Metric

Part No.	Tube O.D.	A	B	C	D	E	F	G	Bore
PH-M6-PC	6mm	37.2 (1.47")	23.7 (0.93")	20.9 (0.82")	19.0 (0.75")	17.0 (0.67")	14.5 (0.57")	74.5 (2.93")	4.0 (0.16")
PH-M8-PC	8mm	38.2 (1.51")	24.7 (0.97")	21.9 (0.86")	20.0 (0.79")	19.0 (0.75")	14.5 (0.57")	76.5 (3.01")	5.0 (0.20")
PH-M10-PC	10mm	39.2 (1.54")	25.7 (1.01")	22.9 (0.90")	21.0 (0.83")	22.0 (0.87")	18.5 (0.73")	78.5 (3.09")	6.0 (0.24")
PH-M12-PC	12mm	38.7 (1.53")	26.7 (1.05")	23.1 (0.91")	22.0 (0.87")	25.0 (0.98")	18.5 (0.73")	77.5 (3.05")	8.0 (0.31")
PH-M14-PC	14mm	42.1 (1.66")	26.7 (1.05")	23.3 (0.92")	22.0 (0.87")	28.0 (1.10")	20.5 (0.81")	84.2 (3.32")	10.0 (0.39")
PH-M16-PC	16mm	45.7 (1.80")	29.7 (1.17")	25.9 (1.02")	25.0 (0.98")	32.0 (1.26")	22.5 (0.89")	91.5 (3.60")	12.0 (0.47")
PH-M18-PC	18mm	57.2 (2.25")	35.6 (1.40")	31.6 (1.24")	29.5 (1.16")	36.0 (1.42")	28.5 (1.12")	114.4 (4.50")	14.0 (0.55")
PH-M20-PC	20mm	54.0 (2.13")	35.6 (1.40")	31.0 (1.22")	29.5 (1.16")	36.0 (1.42")	28.5 (1.12")	108.0 (4.25")	14.0 (0.55")
PH-M22-PC	22mm	60.6 (2.39")	37.6 (1.48")	32.7 (1.29")	31.0 (1.22")	43.0 (1.69")	33.5 (1.32")	121.2 (4.77")	16.0 (0.63")
PH-M25-PC	25mm	66.0 (2.60")	40.3 (1.59")	34.8 (1.37")	33.5 (1.32")	50.0 (1.97")	38.5 (1.52")	131.9 (5.19")	18.0 (0.71")

Dimensions for reference only, subject to change.

Phastite® Tube Connectors

PS Permanent Union Drop Size Straight

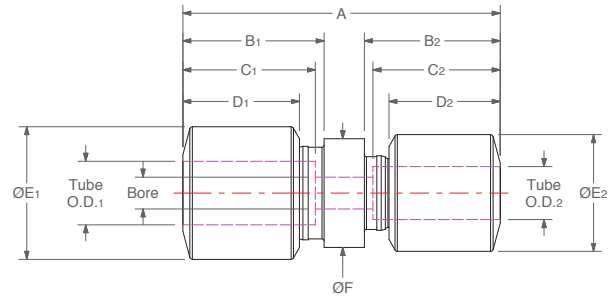
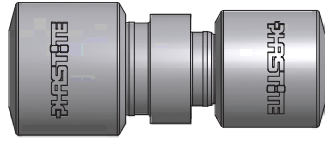

Imperial

Part No.	A	Tube O.D. ₁	B ₁	C ₁	D ₁	E ₁	Tube O.D. ₂	B ₂	C ₂	D ₂	E ₂	F	Bore
PH-6-4-PS	55.5 (2.18")	3/8"	25.7 (1.01")	22.9 (0.90")	21.0 (0.83")	22.0 (0.87")	1/4"	23.7 (0.93")	20.9 (0.82")	19.0 (0.75")	17.0 (0.67")	17.0 (0.67")	4.0 (0.16")
PH-8-6-PS	58.8 (2.31")	1/2"	26.7 (1.05")	23.6 (0.93")	22.0 (0.87")	25.0 (0.98")	3/8"	25.7 (1.01")	22.9 (0.90")	21.0 (0.83")	22.0 (0.87")	20.5 (0.81")	6.0 (0.24")
PH-10-8-PS	74.7 (2.94")	5/8"	29.7 (1.17")	25.9 (1.02")	25.0 (0.98")	32.0 (1.26")	1/2"	26.7 (1.05")	23.6 (0.93")	22.0 (0.87")	25.0 (0.98")	25.0 (0.98")	8.0 (0.31")
PH-12-10-PS	82.5 (3.25")	3/4"	35.6 (1.40")	31.2 (1.23")	29.5 (1.16")	36.0 (1.42")	5/8"	29.7 (1.17")	25.9 (1.02")	25.0 (0.98")	32.0 (1.26")	29.5 (1.16")	12.0 (0.47")
PH-14-12-PS	82.5 (3.25")	7/8"	37.6 (1.48")	32.4 (1.28")	31.0 (1.22")	43.0 (1.69")	3/4"	35.6 (1.40")	31.2 (1.23")	29.5 (1.16")	36.0 (1.42")	34.5 (1.36")	14.0 (0.55")
PH-16-14-PS	93.0 (3.66")	1"	40.3 (1.59")	34.8 (1.37")	33.5 (1.32")	50.0 (1.97")	7/8"	37.6 (1.48")	32.4 (1.28")	31.0 (1.22")	43.0 (1.69")	38.0 (1.50")	16.0 (0.63")

Variants suitable for use on Medium Pressure Tube i.e. 9/16" are available upon request.

PS Permanent Union Drop Size Straight

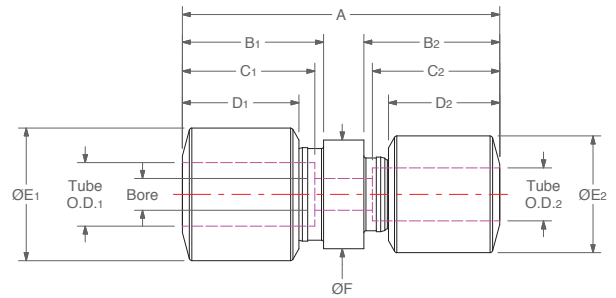
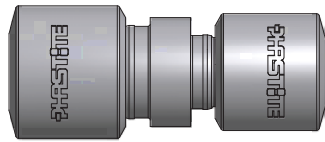

Metric

Part No.	A	Tube O.D. ₁	B ₁	C ₁	D ₁	E ₁	Tube O.D. ₂	B ₂	C ₂	D ₂	E ₂	F	Bore
PH-M8-M6-PS	55.5 (2.18")	8mm	24.7 (0.97")	21.9 (0.86")	20.0 (0.79")	19.0 (0.75")	6mm	23.7 (0.93")	20.9 (0.82")	19.0 (0.75")	17.0 (0.67")	15.4 (0.61")	4.0 (0.16")
PH-M10-M8-PS	56.2 (2.21")	10mm	25.7 (1.01")	22.9 (0.90")	21.0 (0.83")	22.0 (0.87")	8mm	24.7 (0.97")	21.9 (0.86")	20.0 (0.79")	19.0 (0.75")	17.0 (0.67")	5.0 (0.20")
PH-M12-M10-PS	58.1 (2.29")	12mm	26.7 (1.05")	23.1 (0.91")	22.0 (0.87")	25.0 (0.98")	10mm	25.7 (1.01")	22.9 (0.90")	21.0 (0.83")	22.0 (0.87")	20.5 (0.81")	6.0 (0.24")
PH-M14-M12-PS	65.4 (2.58")	14mm	26.7 (1.05")	23.3 (0.92")	22.0 (0.87")	28.0 (1.10")	12mm	26.7 (1.05")	23.1 (0.91")	22.0 (0.87")	25.0 (0.98")	22.5 (0.89")	8.0 (0.31")
PH-M16-M14-PS	74.8 (2.94")	16mm	29.7 (1.17")	25.9 (1.02")	25.0 (0.98")	32.0 (1.26")	14mm	26.7 (1.05")	23.3 (0.92")	22.0 (0.87")	28.0 (1.10")	25.0 (0.98")	10.0 (0.39")
PH-M18-M16-PS	83.8 (3.30")	18mm	35.6 (1.40")	31.6 (1.24")	29.5 (1.16")	36.0 (1.42")	16mm	29.7 (1.17")	25.9 (1.02")	25.0 (0.98")	32.0 (1.26")	29.5 (1.16")	12.0 (0.47")
PH-M20-M18-PS	83.9 (3.30")	20mm	35.6 (1.40")	31.0 (1.22")	29.5 (1.16")	36.0 (1.42")	18mm	35.6 (1.40")	31.6 (1.24")	29.5 (1.16")	36.0 (1.42")	30.5 (1.20")	14.0 (0.55")
PH-M22-M20-PS	83.4 (3.28")	22mm	37.6 (1.48")	32.7 (1.29")	31.0 (1.22")	43.0 (1.69")	20mm	35.6 (1.40")	31.0 (1.22")	29.5 (1.16")	36.0 (1.42")	34.5 (1.36")	14.0 (0.55")
PH-M25-M22-PS	94.0 (3.70")	25mm	40.3 (1.59")	34.8 (1.37")	33.5 (1.32")	50.0 (1.97")	22mm	37.6 (1.48")	32.7 (1.29")	31.0 (1.22")	43.0 (1.69")	38.0 (1.50")	16.0 (0.63")

Dimensions for reference only, subject to change.

Phastite® Tube Connectors

TR Tube Reducer

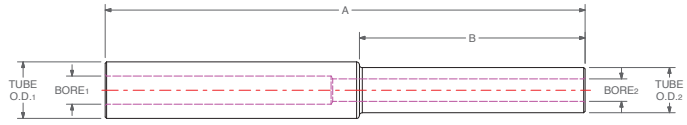
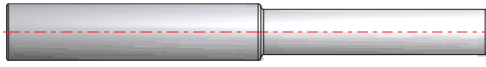

Imperial

Part No.	A	B	Tube O.D. 1	Bore 1	Tube O.D. 2	Bore 2
PH-6-4-TR	85.00 (3.35")	40.00 (1.57")	3/8"	4.70 (0.19")	1/4"	3.05 (0.12")
PH-8-4-TR	85.00 (3.35")	40.00 (1.57")	1/2"	6.35 (0.25")	1/4"	3.05 (0.12")
PH-8-6-TR	85.00 (3.35")	40.00 (1.57")	1/2"	6.35 (0.25")	3/8"	4.70 (0.19")
PH-10-6-TR	125.00 (4.92")	60.00 (2.36")	5/8"	9.53 (0.38")	3/8"	5.31 (0.21")
PH-10-8-TR	125.00 (4.92")	60.00 (2.36")	5/8"	9.53 (0.38")	1/2"	7.16 (0.28")
PH-12-8-TR	125.00 (4.92")	60.00 (2.36")	3/4"	11.13 (0.44")	1/2"	7.16 (0.28")
PH-12-10-TR	125.00 (4.92")	60.00 (2.36")	3/4"	11.13 (0.44")	5/8"	9.53 (0.38")
PH-14-8-TR	125.00 (4.92")	60.00 (2.36")	7/8"	14.30 (0.56")	1/2"	7.87 (0.31")
PH-14-10-TR	125.00 (4.92")	60.00 (2.36")	7/8"	14.30 (0.56")	5/8"	9.78 (0.39")
PH-14-12-TR	125.00 (4.92")	60.00 (2.36")	7/8"	14.30 (0.56")	3/4"	11.13 (0.44")
PH-16-8-TR	125.00 (4.92")	60.00 (2.36")	1"	15.85 (0.62")	1/2"	7.87 (0.31")
PH-16-10-TR	125.00 (4.92")	60.00 (2.36")	1"	15.85 (0.62")	5/8"	9.78 (0.39")
PH-16-12-TR	125.00 (4.92")	60.00 (2.36")	1"	15.85 (0.62")	3/4"	11.13 (0.34")
PH-16-14-TR	125.00 (4.92")	60.00 (2.36")	1"	15.85 (0.62")	7/8"	14.30 (0.56")

Variants suitable for use on Medium Pressure Tube i.e. 9/16" are available upon request.

TR Tube Reducer

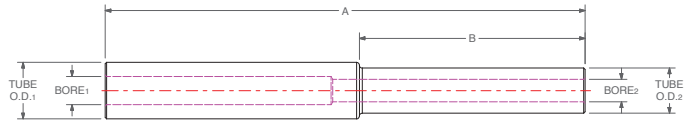
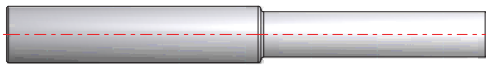

Metric

Part No.	A	B	Tube O.D. 1	Bore 1	Tube O.D. 2	Bore 2
PH-M8-M6-TR	85.00 (3.35")	40.00 (1.57")	8mm	3.60 (0.14")	6mm	2.40 (0.09")
PH-M10-M6-TR	85.00 (3.35")	40.00 (1.57")	10mm	5.00 (0.20")	6mm	2.00 (0.08")
PH-M10-M8-TR	85.00 (3.35")	40.00 (1.57")	10mm	5.00 (0.20")	8mm	4.00 (0.16")
PH-M12-M6-TR	85.00 (3.35")	40.00 (1.57")	12mm	6.00 (0.24")	6mm	3.00 (0.12")
PH-M12-M8-TR	85.00 (3.35")	40.00 (1.57")	12mm	6.00 (0.24")	8mm	4.00 (0.16")
PH-M12-M10-TR	85.00 (3.35")	40.00 (1.57")	12mm	6.00 (0.24")	10mm	5.00 (0.20")
PH-M14-M10-TR	125.00 (4.92")	60.00 (2.36")	14mm	8.00 (0.31")	10mm	5.00 (0.20")
PH-M14-M12-TR	125.00 (4.92")	60.00 (2.36")	14mm	8.00 (0.31")	12mm	6.40 (0.25")
PH-M16-M12-TR	125.00 (4.92")	60.00 (2.36")	16mm	9.00 (0.35")	12mm	6.40 (0.25")
PH-M16-M14-TR	125.00 (4.92")	60.00 (2.36")	16mm	9.00 (0.35")	14mm	8.00 (0.31")
PH-M18-M14-TR	125.00 (4.92")	60.00 (2.36")	18mm	11.00 (0.43")	14mm	8.00 (0.31")
PH-M18-M16-TR	125.00 (4.92")	60.00 (2.36")	18mm	11.00 (0.43")	16mm	9.00 (0.35")
PH-M20-M16-TR	125.00 (4.92")	60.00 (2.36")	20mm	12.00 (0.47")	16mm	9.00 (0.35")
PH-M20-M18-TR	125.00 (4.92")	60.00 (2.36")	20mm	12.00 (0.47")	18mm	11.00 (0.43")
PH-M22-M16-TR	125.00 (4.92")	60.00 (2.36")	22mm	14.00 (0.55")	16mm	10.00 (0.39")
PH-M22-M18-TR	125.00 (4.92")	60.00 (2.36")	22mm	14.00 (0.55")	18mm	11.00 (0.43")
PH-M22-M20-TR	125.00 (4.92")	60.00 (2.36")	22mm	14.00 (0.55")	20mm	12.00 (0.47")
PH-M25-M12-TR	125.00 (4.92")	60.00 (2.36")	25mm	16.00 (0.63")	12mm	12.00 (0.28")
PH-M25-M14-TR	125.00 (4.92")	60.00 (2.36")	25mm	16.00 (0.63")	14mm	8.40 (0.33")
PH-M25-M16-TR	125.00 (4.92")	60.00 (2.36")	25mm	16.00 (0.63")	16mm	10.00 (0.39")
PH-M25-M18-TR	125.00 (4.92")	60.00 (2.36")	25mm	16.00 (0.63")	18mm	11.00 (0.43")
PH-M25-M20-TR	125.00 (4.92")	60.00 (2.36")	25mm	16.00 (0.63")	20mm	12.00 (0.47")
PH-M25-M22-TR	125.00 (4.92")	60.00 (2.36")	25mm	16.00 (0.63")	22mm	14.00 (0.55")

Dimensions for reference only, subject to change.

Phastite® Tube Connectors

TPS Termination to Permanent Union Equal Straight

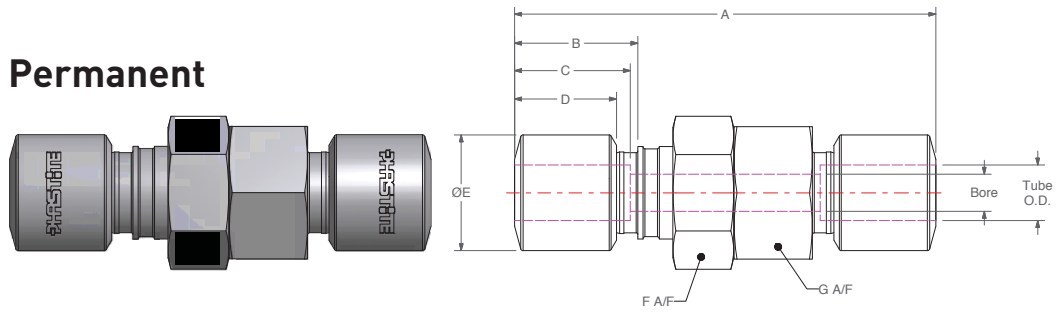

Imperial

Part No.	Tube O.D.	A	B	C	D	E	F	G	Bore
PH-4-4-TPS	1/4"	76.1 (3.00")	23.7 (0.93")	20.9 (0.82")	19.0 (0.75")	17.0 (0.67")	20.6 (0.81")	19.1 (0.75")	4.0 (0.16")
PH-6-6-TPS	3/8"	79.4 (3.13")	25.7 (1.01")	22.9 (0.90")	21.0 (0.83")	22.0 (0.87")	25.4 (1.00")	25.4 (1.00")	6.0 (0.24")
PH-8-8-TPS	1/2"	80.6 (3.17")	26.7 (1.05")	23.6 (0.93")	22.0 (0.87")	25.0 (0.98")	28.6 (1.13")	28.6 (1.13")	8.0 (0.31")
PH-10-10-TPS	5/8"	89.7 (3.53")	29.7 (1.17")	25.9 (1.02")	25.0 (0.98")	32.0 (1.26")	34.9 (1.37")	34.9 (1.37")	12.0 (0.47")
PH-12-12-TPS	3/4"	107.5 (4.23")	35.6 (1.40")	31.2 (1.23")	29.5 (1.16")	36.0 (1.42")	38.1 (1.50")	38.1 (1.50")	14.0 (0.55")
PH-14-14-TPS	7/8"	111.2 (4.38")	37.6 (1.48")	32.4 (1.28")	31.0 (1.22")	43.0 (1.69")	44.5 (1.75")	41.3 (1.63")	16.0 (0.63")
PH-16-16-TPS	1"	124.3 (4.89")	40.3 (1.59")	34.8 (1.37")	33.5 (1.32")	50.0 (1.97")	50.8 (2.00")	47.6 (1.87")	18.0 (0.71")

Variants suitable for use on Medium Pressure Tube i.e. 9/16" are available upon request.

TPS Termination to Permanent Union Equal Straight

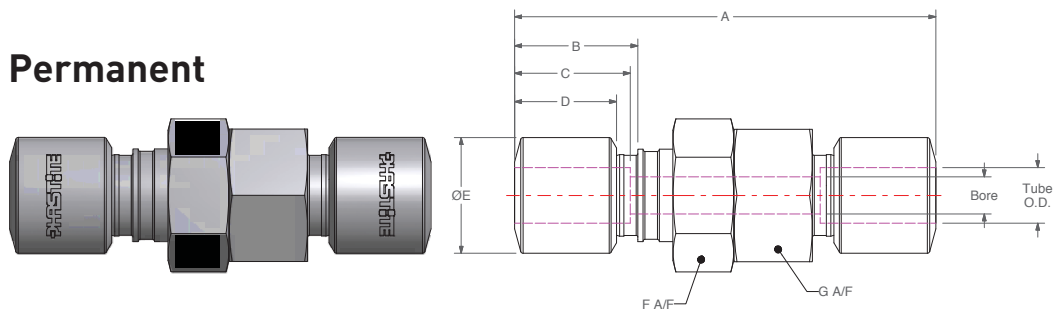

Metric

Part No.	Tube O.D.	A	B	C	D	E	F	G	Bore
PH-M6-M6-TPS	6mm	76.4 (3.01")	23.7 (0.93")	20.9 (0.82")	19.0 (0.75")	17.0 (0.67")	20.6 (0.81")	19.1 (0.75")	4.0 (0.16")
PH-M8-M8-TPS	8mm	78.7 (3.10")	24.7 (0.97")	21.9 (0.86")	20.0 (0.79")	19.0 (0.75")	25.4 (1.00")	25.4 (1.00")	5.0 (0.20")
PH-M10-M10-TPS	10mm	79.4 (3.13")	25.7 (1.01")	22.9 (0.90")	21.0 (0.83")	22.0 (0.87")	25.4 (1.00")	25.4 (1.00")	8.0 (0.31")
PH-M12-M12-TPS	12mm	79.9 (3.15")	26.7 (1.05")	23.1 (0.91")	22.0 (0.87")	25.0 (0.98")	28.6 (1.13")	28.6 (1.13")	8.0 (0.31")
PH-M14-M14-TPS	14mm	82.2 (3.23")	26.7 (1.05")	23.3 (0.92")	22.0 (0.87")	28.0 (1.10")	30.2 (1.19")	30.0 (1.18")	10.0 (0.39")
PH-M16-M16-TPS	16mm	89.9 (3.54")	29.7 (1.17")	25.9 (1.02")	25.0 (0.98")	32.0 (1.26")	34.9 (1.37")	34.9 (1.37")	12.0 (0.47")
PH-M18-M18-TPS	18mm	106.8 (4.20")	35.6 (1.40")	31.6 (1.24")	29.5 (1.16")	36.0 (1.42")	38.1 (1.50")	38.1 (1.50")	14.0 (0.55")
PH-M20-M20-TPS	20mm	108.6 (4.28")	35.6 (1.40")	31.0 (1.22")	29.5 (1.16")	36.0 (1.42")	38.1 (1.50")	38.1 (1.50")	14.0 (0.55")
PH-M22-M22-TPS	22mm	110.9 (4.37")	37.6 (1.48")	32.7 (1.29")	31.0 (1.22")	43.0 (1.69")	44.5 (1.75")	41.3 (1.63")	16.0 (0.63")
PH-M25-M25-TPS	25mm	123.9 (4.88")	40.3 (1.59")	34.8 (1.37")	33.5 (1.32")	50.0 (1.97")	50.8 (2.00")	47.6 (1.87")	18.0 (0.71")

Dimensions for reference only, subject to change.

Phastite® Tube Connectors

TMS - N Termination Male Straight - NPT

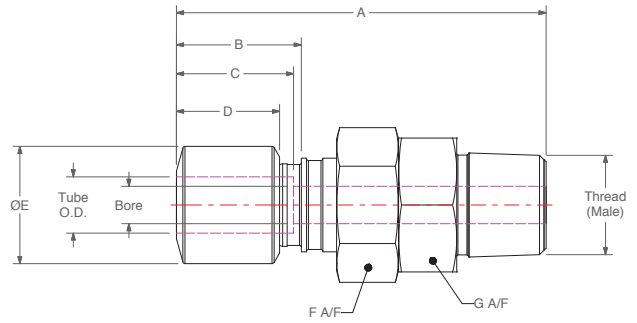
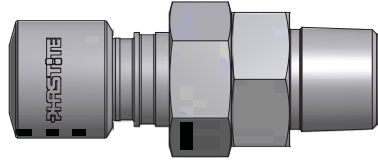

Imperial

Part No.	Tube O.D.	A	B	C	D	E	F	G	Bore	Thread
PH-4-4N-TMS	1/4"	67.1 (2.64")	23.7 (0.93")	20.9 (0.82")	19.0 (0.75")	17.0 (0.67")	20.6 (0.81")	19.0 (0.75")	4.0 (0.16")	1/4-18 NPT
PH-6-4N-TMS	3/8"	69.6 (2.74")	25.7 (1.01")	22.9 (0.90")	21.0 (0.83")	22.0 (0.87")	25.4 (1.00")	25.4 (1.00")	6.0 (0.24")	1/4-18 NPT
PH-6-6N-TMS	3/8"	69.6 (2.74")	25.7 (1.01")	22.9 (0.90")	21.0 (0.83")	22.0 (0.87")	25.4 (1.00")	25.4 (1.00")	6.0 (0.24")	3/8-18 NPT
PH-8-8N-TMS	1/2"	77.6 (3.06")	26.7 (1.05")	23.6 (0.93")	22.0 (0.87")	25.0 (0.98")	28.6 (1.13")	28.6 (1.13")	8.0 (0.31")	1/2-14 NPT
PH-10-12N-TMS	5/8"	84.6 (3.33")	29.7 (1.17")	25.9 (1.02")	25.0 (0.98")	32.0 (1.26")	34.9 (1.37")	34.9 (1.37")	12.0 (0.47")	3/4-14 NPT
PH-12-12N-TMS	3/4"	90.6 (3.57")	35.6 (1.40")	31.2 (1.23")	29.5 (1.16")	36.0 (1.42")	38.1 (1.50")	38.1 (1.50")	14.0 (0.55")	3/4-14 NPT
PH-14-16N-TMS	7/8"	97.6 (3.84")	37.6 (1.48")	32.4 (1.28")	31.0 (1.22")	43.0 (1.69")	44.5 (1.75")	44.5 (1.75")	16.0 (0.63")	1-11.5 NPT
PH-16-16N-TMS	1"	100.3 (3.95")	40.3 (1.59")	34.8 (1.37")	33.5 (1.32")	50.0 (1.97")	50.8 (2.00")	47.6 (1.87")	18.0 (0.71")	1-11.5 NPT

Variants suitable for use on Medium Pressure Tube i.e. 9/16" are available upon request.

TMS - N Termination Male Straight - NPT

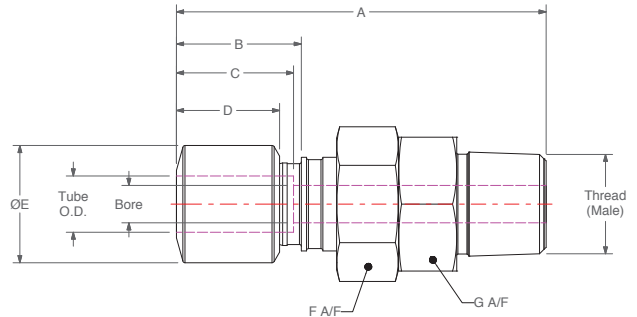
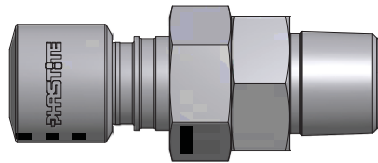

Metric

Part No.	Tube O.D.	A	B	C	D	E	F	G	Bore	Thread
PH-M6-4N-TMS	6mm	67.4 (2.65")	23.7 (0.93")	20.9 (0.82")	19.0 (0.75")	17.0 (0.67")	20.6 (0.81")	19.0 (0.75")	4.0 (0.16")	1/4-18 NPT
PH-M8-4N-TMS	8mm	68.6 (2.70")	24.7 (0.97")	21.9 (0.86")	20.0 (0.79")	19.0 (0.75")	25.4 (1.00")	25.4 (1.00")	5.0 (0.20")	1/4-18 NPT
PH-M8-6N-TMS	8mm	68.6 (2.70")	24.7 (0.97")	21.9 (0.86")	20.0 (0.79")	19.0 (0.75")	25.4 (1.00")	25.4 (1.00")	6.0 (0.24")	3/8-18 NPT
PH-M10-4N-TMS	10mm	69.6 (2.74")	25.7 (1.01")	22.9 (0.90")	21.0 (0.83")	22.0 (0.87")	25.4 (1.00")	25.4 (1.00")	6.0 (0.24")	1/4-18 NPT
PH-M10-6N-TMS	10mm	69.6 (2.74")	25.7 (1.01")	22.9 (0.90")	21.0 (0.83")	22.0 (0.87")	25.4 (1.00")	25.4 (1.00")	8.0 (0.31")	3/8-18 NPT
PH-M12-8N-TMS	12mm	77.7 (3.06")	26.7 (1.05")	23.1 (0.91")	22.0 (0.87")	25.0 (0.98")	28.6 (1.13")	28.6 (1.13")	8.0 (0.31")	1/2-14 NPT
PH-M14-8N-TMS	14mm	79.7 (3.14")	26.7 (1.05")	23.3 (0.92")	22.0 (0.87")	28.0 (1.10")	30.2 (1.19")	31.8 (1.25")	10.0 (0.39")	1/2-14 NPT
PH-M16-12N-TMS	16mm	84.6 (3.33")	29.7 (1.17")	25.9 (1.02")	25.0 (0.98")	32.0 (1.26")	34.9 (1.37")	34.9 (1.37")	12.0 (0.47")	3/4-14 NPT
PH-M18-12N-TMS	18mm	90.6 (3.57")	35.6 (1.40")	31.6 (1.24")	29.5 (1.16")	36.0 (1.42")	38.1 (1.50")	38.1 (1.50")	14.0 (0.55")	3/4-14 NPT
PH-M20-12N-TMS	20mm	90.6 (3.57")	35.6 (1.40")	31.0 (1.22")	29.5 (1.16")	36.0 (1.42")	38.1 (1.50")	38.1 (1.50")	14.0 (0.55")	3/4-14 NPT
PH-M22-16N-TMS	22mm	97.6 (3.84")	37.6 (1.48")	32.7 (1.29")	31.0 (1.22")	43.0 (1.69")	44.5 (1.75")	44.5 (1.75")	16.0 (0.63")	1-11.5 NPT
PH-M25-16N-TMS	25mm	100.3 (3.95")	40.3 (1.59")	34.8 (1.37")	33.5 (1.32")	50.0 (1.97")	50.8 (2.00")	47.6 (1.87")	18.0 (0.71")	1-11.5 NPT

Dimensions for reference only, subject to change.

Phastite® Tube Connectors

TFS - N Termination Female Straight - NPT

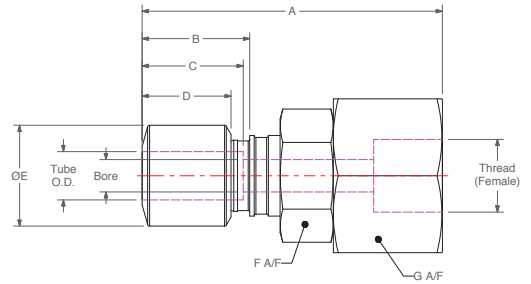
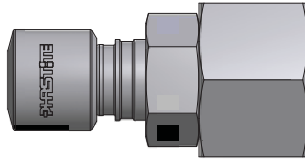

Imperial

Part No.	Tube O.D.	A	B	C	D	E	F	G	Bore	Thread
PH-4-4N-TFS	1/4"	68.1 (2.68")	23.7 (0.93")	20.9 (0.82")	19.0 (0.75")	17.0 (0.67")	20.6 (0.81")	28.6 (1.13")	4.0 (0.16")	1/4-18 NPT
PH-6-4N-TFS	3/8"	70.6 (2.78")	25.7 (1.01")	22.9 (0.90")	21.0 (0.83")	22.0 (0.87")	25.4 (1.00")	25.4 (1.00")	6.0 (0.24")	1/4-18 NPT
PH-6-6N-TFS	3/8"	72.1 (2.84")	25.7 (1.01")	22.9 (0.90")	21.0 (0.83")	22.0 (0.87")	25.4 (1.00")	25.4 (1.00")	6.0 (0.24")	3/8-18 NPT
PH-8-8N-TFS	1/2"	77.6 (3.06")	26.7 (1.05")	23.6 (0.93")	22.0 (0.87")	25.0 (0.98")	28.6 (1.13")	38.1 (1.50")	8.0 (0.31")	1/2-14 NPT
PH-10-12N-TFS	5/8"	80.6 (3.18")	29.7 (1.17")	25.9 (1.02")	25.0 (0.98")	32.0 (1.26")	34.9 (1.37")	38.1 (1.50")	12.0 (0.47")	3/4-14 NPT
PH-12-12N-TFS	3/4"	86.6 (3.41")	35.6 (1.40")	31.2 (1.23")	29.5 (1.16")	36.0 (1.42")	38.1 (1.50")	38.1 (1.50")	14.0 (0.55")	3/4-14 NPT
PH-14-16N-TFS	7/8"	92.6 (3.65")	37.6 (1.48")	32.4 (1.28")	31.0 (1.22")	43.0 (1.69")	44.5 (1.75")	47.6 (1.87")	16.0 (0.63")	1-11.5 NPT
PH-16-16N-TFS	1"	95.3 (3.75")	40.3 (1.59")	34.8 (1.37")	33.5 (1.32")	50.0 (1.97")	50.8 (2.00")	47.6 (1.87")	18.0 (0.71")	1-11.5 NPT

Variants suitable for use on Medium Pressure Tube i.e. 9/16" are available upon request.

TFS - N Termination Female Straight - NPT

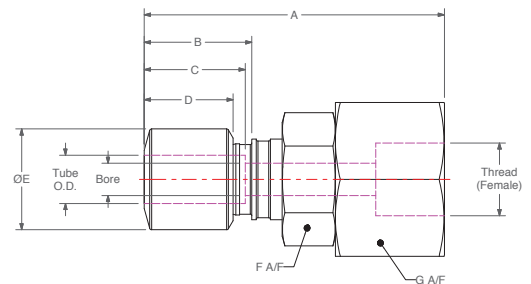
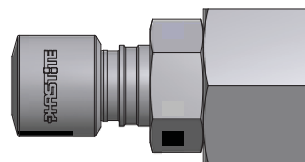

Metric

Part No.	Tube O.D.	A	B	C	D	E	F	G	Bore	Thread
PH-M6-4N-TFS	6mm	68.4 (2.69")	23.7 (0.93")	20.9 (0.82")	19.0 (0.75")	17.0 (0.67")	20.6 (0.81")	28.6 (1.13")	4.0 (0.16")	1/4-18 NPT
PH-M8-4N-TFS	8mm	69.6 (2.74")	24.7 (0.97")	21.9 (0.86")	20.0 (0.79")	19.0 (0.75")	25.4 (1.00")	25.4 (1.00")	5.0 (0.20")	1/4-18 NPT
PH-M8-6N-TFS	8mm	71.1 (2.80")	24.7 (0.97")	21.9 (0.86")	20.0 (0.79")	19.0 (0.75")	25.4 (1.00")	25.4 (1.00")	6.0 (0.24")	3/8-18 NPT
PH-M10-4N-TFS	10mm	70.6 (2.78")	25.7 (1.01")	22.9 (0.90")	21.0 (0.83")	22.0 (0.87")	25.4 (1.00")	25.4 (1.00")	6.0 (0.24")	1/4-18 NPT
PH-M10-6N-TFS	10mm	72.1 (2.84")	25.7 (1.01")	22.9 (0.90")	21.0 (0.83")	22.0 (0.87")	25.4 (1.00")	25.4 (1.00")	8.0 (0.31")	3/8-18 NPT
PH-M12-8N-TFS	12mm	77.7 (3.06")	26.7 (1.05")	23.1 (0.91")	22.0 (0.87")	25.0 (0.98")	28.6 (1.13")	38.1 (1.50")	8.0 (0.31")	1/2-14 NPT
PH-M14-8N-TFS	14mm	77.7 (3.06")	26.7 (1.05")	23.3 (0.92")	22.0 (0.87")	28.0 (1.10")	30.2 (1.19")	38.1 (1.50")	10.0 (0.39")	1/2-14 NPT
PH-M16-12N-TFS	16mm	80.6 (3.18")	29.7 (1.17")	25.9 (1.02")	25.0 (0.98")	32.0 (1.26")	34.9 (1.37")	38.1 (1.50")	12.0 (0.47")	3/4-14 NPT
PH-M18-12N-TFS	18mm	86.6 (3.41")	35.6 (1.40")	31.6 (1.24")	29.5 (1.16")	36.0 (1.42")	38.1 (1.50")	38.1 (1.50")	14.0 (0.55")	3/4-14 NPT
PH-M20-12N-TFS	20mm	86.6 (3.41")	35.6 (1.40")	31.0 (1.22")	29.5 (1.16")	36.0 (1.42")	38.1 (1.50")	38.1 (1.50")	14.0 (0.55")	3/4-14 NPT
PH-M22-16N-TFS	22mm	92.6 (3.65")	37.6 (1.48")	32.7 (1.29")	31.0 (1.22")	43.0 (1.69")	44.5 (1.75")	47.6 (1.87")	16.0 (0.63")	1-11.5 NPT
PH-M25-16N-TFS	25mm	95.3 (3.75")	40.3 (1.59")	34.8 (1.37")	33.5 (1.32")	50.0 (1.97")	50.8 (2.00")	47.6 (1.87")	18.0 (0.71")	1-11.5 NPT

Dimensions for reference only, subject to change.

Phastite® Tube Connectors

TMS - K Termination Male Straight - BSPT

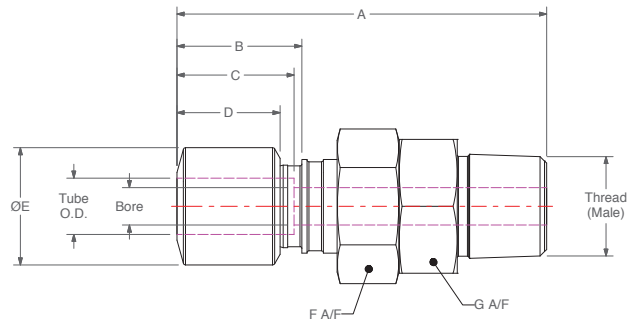
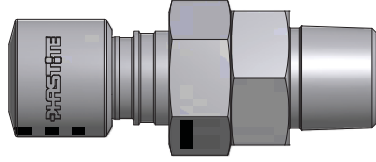

Imperial

Part No.	Tube O.D.	A	B	C	D	E	F	G	Bore	Thread
PH-4-4K-TMS	1/4"	67.1 (2.64")	23.7 (0.93")	20.9 (0.82")	19.0 (0.75")	17.0 (0.67")	20.6 (0.81")	19.0 (0.75")	4.0 (0.16")	1/4-19 BSPT
PH-6-4K-TMS	3/8"	69.6 (2.74")	25.7 (1.01")	22.9 (0.90")	21.0 (0.83")	22.0 (0.87")	25.4 (1.00")	25.4 (1.00")	6.0 (0.24")	1/4-19 BSPT
PH-6-6K-TMS	3/8"	69.6 (2.74")	25.7 (1.01")	22.9 (0.90")	21.0 (0.83")	22.0 (0.87")	25.4 (1.00")	25.4 (1.00")	6.0 (0.24")	3/8-19 BSPT
PH-8-8K-TMS	1/2"	77.6 (3.06")	26.7 (1.05")	23.6 (0.93")	22.0 (0.87")	25.0 (0.98")	28.6 (1.13")	28.6 (1.13")	8.0 (0.31")	1/2-14 BSPT
PH-10-12K-TMS	5/8"	84.6 (3.33")	29.7 (1.17")	25.9 (1.02")	25.0 (0.98")	32.0 (1.26")	34.9 (1.37")	34.9 (1.37")	12.0 (0.47")	3/4-14 BSPT
PH-12-12K-TMS	3/4"	90.6 (3.57")	35.6 (1.40")	31.2 (1.23")	29.5 (1.16")	36.0 (1.42")	38.1 (1.50")	38.1 (1.50")	14.0 (0.55")	3/4-14 BSPT
PH-14-16K-TMS	7/8"	97.6 (3.84")	37.6 (1.48")	32.4 (1.28")	31.0 (1.22")	43.0 (1.69")	44.5 (1.75")	44.5 (1.75")	16.0 (0.63")	1-11.5 BSPT
PH-16-16K-TMS	1"	100.3 (3.95")	40.3 (1.59")	34.8 (1.37")	33.5 (1.32")	50.0 (1.97")	50.8 (2.00")	47.6 (1.87")	18.0 (0.71")	1-11.5 BSPT

Variants suitable for use on Medium Pressure Tube i.e. 9/16" are available upon request.

TMS - K Termination Male Straight - BSPT

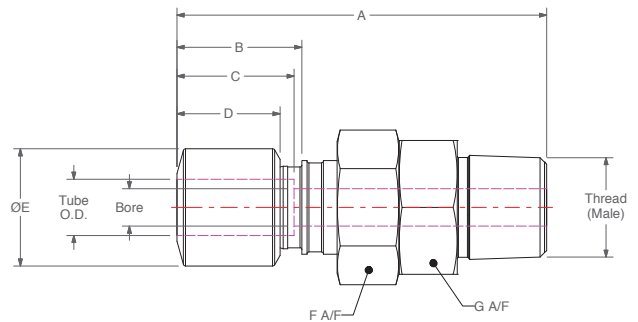
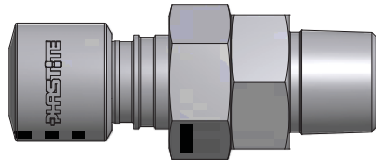

Metric

Part No.	Tube O.D.	A	B	C	D	E	F	G	Bore	Thread
PH-M6-4K-TMS	6mm	67.4 (2.65")	23.7 (0.93")	20.9 (0.82")	19.0 (0.75")	17.0 (0.67")	20.6 (0.81")	19.0 (0.75")	4.0 (0.16")	1/4-19 BSPT
PH-M8-4K-TMS	8mm	68.6 (2.70")	24.7 (0.97")	21.9 (0.86")	20.0 (0.79")	19.0 (0.75")	25.4 (1.00")	25.4 (1.00")	5.0 (0.20")	1/4-19 BSPT
PH-M8-6K-TMS	8mm	68.6 (2.70")	24.7 (0.97")	21.9 (0.86")	20.0 (0.79")	19.0 (0.75")	25.4 (1.00")	25.4 (1.00")	6.0 (0.24")	3/8-19 BSPT
PH-M10-4K-TMS	10mm	69.6 (2.74")	25.7 (1.01")	22.9 (0.90")	21.0 (0.83")	22.0 (0.87")	25.4 (1.00")	25.4 (1.00")	6.0 (0.24")	1/4-19 BSPT
PH-M10-6K-TMS	10mm	69.6 (2.74")	25.7 (1.01")	22.9 (0.90")	21.0 (0.83")	22.0 (0.87")	25.4 (1.00")	25.4 (1.00")	8.0 (0.31")	3/8-19 BSPT
PH-M12-8K-TMS	12mm	77.7 (3.06")	26.7 (1.05")	23.1 (0.91")	22.0 (0.87")	25.0 (0.98")	28.6 (1.13")	28.6 (1.13")	8.0 (0.31")	1/2-14 BSPT
PH-M14-8K-TMS	14mm	79.7 (3.14")	26.7 (1.05")	23.3 (0.92")	22.0 (0.87")	28.0 (1.10")	30.2 (1.19")	31.8 (1.25")	10.0 (0.39")	1/2-14 BSPT
PH-M16-12K-TMS	16mm	84.6 (3.33")	29.7 (1.17")	25.9 (1.02")	25.0 (0.98")	32.0 (1.26")	34.9 (1.37")	34.9 (1.37")	12.0 (0.47")	3/4-14 BSPT
PH-M18-12K-TMS	18mm	90.6 (3.57")	35.6 (1.40")	31.6 (1.24")	29.5 (1.16")	36.0 (1.42")	38.1 (1.50")	38.1 (1.50")	14.0 (0.55")	3/4-14 BSPT
PH-M20-12K-TMS	20mm	90.6 (3.57")	35.6 (1.40")	31.0 (1.22")	29.5 (1.16")	36.0 (1.42")	38.1 (1.50")	38.1 (1.50")	14.0 (0.55")	3/4-14 BSPT
PH-M22-16K-TMS	22mm	97.6 (3.84")	37.6 (1.48")	32.7 (1.29")	31.0 (1.22")	43.0 (1.69")	44.5 (1.75")	44.5 (1.75")	16.0 (0.63")	1-11 BSPT
PH-M25-16K-TMS	25mm	100.3 (3.95")	40.3 (1.59")	34.8 (1.37")	33.5 (1.32")	50.0 (1.97")	50.8 (2.00")	47.6 (1.87")	18.0 (0.71")	1-11 BSPT

Dimensions for reference only, subject to change.

Phastite® Tube Connectors

TFS - K Termination Female Straight - BSPT

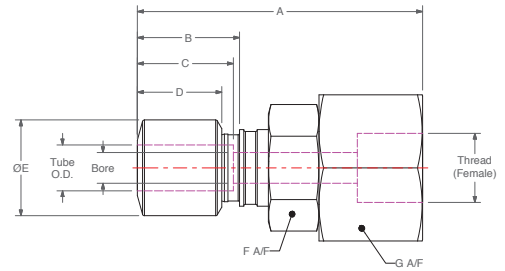
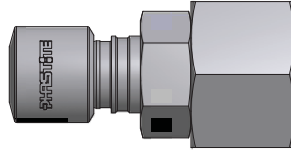

Imperial

Part No.	Tube O.D.	A	B	C	D	E	F	G	Bore	Thread
PH-4-4K-TFS	1/4"	68.1 (2.68")	23.7 (0.93")	20.9 (0.82")	19.0 (0.75")	17.0 (0.67")	20.6 (0.81")	28.6 (1.13")	4.0 (0.16")	1/4-19 BSPT
PH-6-4K-TFS	3/8"	70.6 (2.78")	25.7 (1.01")	22.9 (0.90")	21.0 (0.83")	22.0 (0.87")	25.4 (1.00")	25.4 (1.00")	6.0 (0.24")	1/4-19 BSPT
PH-6-6K-TFS	3/8"	72.1 (2.84")	25.7 (1.01")	22.9 (0.90")	21.0 (0.83")	22.0 (0.87")	25.4 (1.00")	25.4 (1.00")	6.0 (0.24")	3/8-19 BSPT
PH-8-8K-TFS	1/2"	77.6 (3.06")	26.7 (1.05")	23.6 (0.93")	22.0 (0.87")	25.0 (0.98")	28.6 (1.13")	38.1 (1.50")	8.0 (0.31")	1/2-14 BSPT
PH-10-12K-TFS	5/8"	80.6 (3.18")	29.7 (1.17")	25.9 (1.02")	25.0 (0.98")	32.0 (1.26")	34.9 (1.37")	38.1 (1.50")	12.0 (0.47")	3/4-14 BSPT
PH-12-12K-TFS	3/4"	86.6 (3.41")	35.6 (1.40")	31.2 (1.23")	29.5 (1.16")	36.0 (1.42")	38.1 (1.50")	38.1 (1.50")	14.0 (0.55")	3/4-14 BSPT
PH-14-16K-TFS	7/8"	92.6 (3.65")	37.6 (1.48")	32.4 (1.28")	31.0 (1.22")	43.0 (1.69")	44.5 (1.75")	47.6 (1.87")	16.0 (0.63")	1-11.5 BSPT
PH-16-16K-TFS	1"	95.3 (3.75")	40.3 (1.59")	34.8 (1.37")	33.5 (1.32")	50.0 (1.97")	50.8 (2.00")	47.6 (1.87")	18.0 (0.71")	1-11.5 BSPT

Variants suitable for use on Medium Pressure Tube i.e. 9/16" are available upon request.

TFS - K Termination Tube Female Straight - BSPT

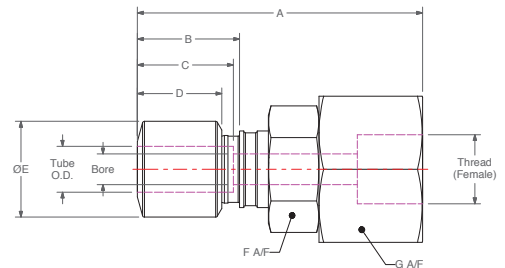
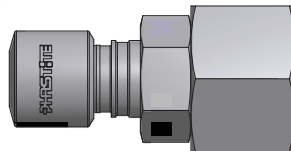

Metric

Part No.	Tube O.D.	A	B	C	D	E	F	G	Bore	Thread
PH-M6-4K-TFS	6mm	68.4 (2.69")	23.7 (0.93")	20.9 (0.82")	19.0 (0.75")	17.0 (0.67")	20.6 (0.81")	28.6 (1.13")	4.0 (0.16")	1/4-19 BSPT
PH-M8-4K-TFS	8mm	69.6 (2.74")	24.7 (0.97")	21.9 (0.86")	20.0 (0.79")	19.0 (0.75")	25.4 (1.00")	25.4 (1.00")	5.0 (0.20")	1/4-19 BSPT
PH-M8-6K-TFS	8mm	71.1 (2.80")	24.7 (0.97")	21.9 (0.86")	20.0 (0.79")	19.0 (0.75")	25.4 (1.00")	25.4 (1.00")	6.0 (0.24")	3/8-19 BSPT
PH-M10-4K-TFS	10mm	70.6 (2.78")	25.7 (1.01")	22.9 (0.90")	21.0 (0.83")	22.0 (0.87")	25.4 (1.00")	25.4 (1.00")	6.0 (0.24")	1/4-19 BSPT
PH-M10-6K-TFS	10mm	72.1 (2.84")	25.7 (1.01")	22.9 (0.90")	21.0 (0.83")	22.0 (0.87")	25.4 (1.00")	25.4 (1.00")	8.0 (0.31")	3/8-19 BSPT
PH-M12-8K-TFS	12mm	77.7 (3.06")	26.7 (1.05")	23.1 (0.91")	22.0 (0.87")	25.0 (0.98")	28.6 (1.13")	38.1 (1.50")	8.0 (0.31")	1/2-14 BSPT
PH-M14-8K-TFS	14mm	77.7 (3.06")	26.7 (1.05")	23.3 (0.92")	22.0 (0.87")	28.0 (1.10")	30.2 (1.19")	38.1 (1.50")	10.0 (0.39")	1/2-14 BSPT
PH-M16-12K-TFS	16mm	80.6 (3.18")	29.7 (1.17")	25.9 (1.02")	25.0 (0.98")	32.0 (1.26")	34.9 (1.37")	38.1 (1.50")	12.0 (0.47")	3/4-14 BSPT
PH-M18-12K-TFS	18mm	86.6 (3.41")	35.6 (1.40")	31.6 (1.24")	29.5 (1.16")	36.0 (1.42")	38.1 (1.50")	38.1 (1.50")	14.0 (0.55")	3/4-14 BSPT
PH-M20-12K-TFS	20mm	86.6 (3.41")	35.6 (1.40")	31.0 (1.22")	29.5 (1.16")	36.0 (1.42")	38.1 (1.50")	38.1 (1.50")	14.0 (0.55")	3/4-14 BSPT
PH-M22-16K-TFS	22mm	92.6 (3.65")	37.6 (1.48")	32.7 (1.29")	31.0 (1.22")	43.0 (1.69")	44.5 (1.75")	47.6 (1.87")	16.0 (0.63")	1-11 BSPT
PH-M25-16K-TFS	25mm	95.3 (3.75")	40.3 (1.59")	34.8 (1.37")	33.5 (1.32")	50.0 (1.97")	50.8 (2.00")	47.6 (1.87")	18.0 (0.71")	1-11 BSPT

Dimensions for reference only, subject to change.

Phastite® Tube Connectors

TMS - R Termination Male Straight - BSPP

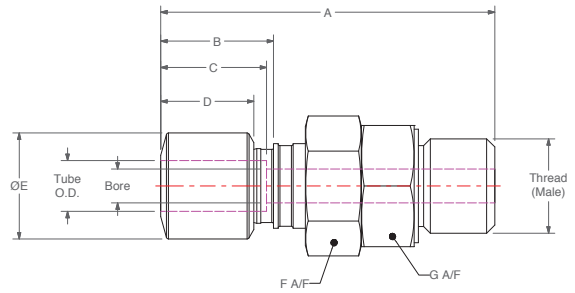
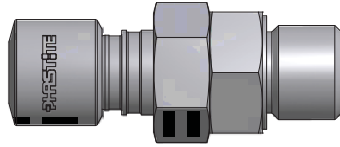

Imperial

Part No.	Tube O.D.	A	B	C	D	E	F	G	Bore	Thread
PH-4-4R-TMS	1/4"	67.1 (2.64")	23.7 (0.93")	20.9 (0.82")	19.0 (0.75")	17.0 (0.67")	20.6 (0.81")	19.0 (0.75")	4.0 (0.16")	1/4-19 BSPP
PH-6-4R-TMS	3/8"	69.6 (2.74")	25.7 (1.01")	22.9 (0.90")	21.0 (0.83")	22.0 (0.87")	25.4 (1.00")	25.4 (1.00")	6.0 (0.24")	1/4-19 BSPP
PH-6-6R-TMS	3/8"	69.6 (2.74")	25.7 (1.01")	22.9 (0.90")	21.0 (0.83")	22.0 (0.87")	25.4 (1.00")	25.4 (1.00")	6.0 (0.24")	3/8-19 BSPP
PH-8-8R-TMS	1/2"	77.6 (3.06")	26.7 (1.05")	23.6 (0.93")	22.0 (0.87")	25.0 (0.98")	28.6 (1.13")	28.6 (1.13")	8.0 (0.31")	1/2-14 BSPP
PH-10-12R-TMS	5/8"	84.6 (3.33")	29.7 (1.17")	25.9 (1.02")	25.0 (0.98")	32.0 (1.26")	34.9 (1.37")	34.9 (1.37")	12.0 (0.47")	3/4-14 BSPP
PH-12-12R-TMS	3/4"	90.6 (3.57")	35.6 (1.40")	31.2 (1.23")	29.5 (1.16")	36.0 (1.42")	38.1 (1.50")	38.1 (1.50")	14.0 (0.55")	3/4-14 BSPP
PH-14-16R-TMS	7/8"	97.6 (3.84")	37.6 (1.48")	32.4 (1.28")	31.0 (1.22")	43.0 (1.69")	44.5 (1.75")	44.5 (1.75")	16.0 (0.63")	1-11.5 BSPP
PH-16-16R-TMS	1"	100.3 (3.95")	40.3 (1.59")	34.8 (1.37")	33.5 (1.32")	50.0 (1.97")	50.8 (2.00")	47.6 (1.87")	18.0 (0.71")	1-11.5 BSPP

Variants suitable for use on Medium Pressure Tube i.e. 9/16" are available upon request.

TMS - R Termination Male Straight - BSPP

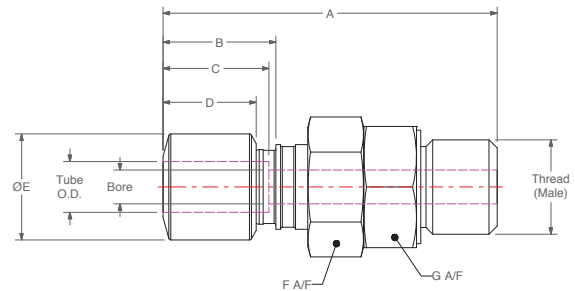
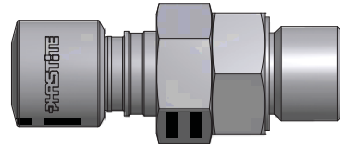

Metric

Part No.	Tube O.D.	A	B	C	D	E	F	G	Bore	Thread
PH-M6-4R-TMS	6mm	67.4 (2.65")	23.7 (0.93")	20.9 (0.82")	19.0 (0.75")	17.0 (0.67")	20.6 (0.81")	19.0 (0.75")	4.0 (0.16")	1/4-19 BSPP
PH-M8-4R-TMS	8mm	68.6 (2.70")	24.7 (0.97")	21.9 (0.86")	20.0 (0.79")	19.0 (0.75")	25.4 (1.00")	25.4 (1.00")	5.0 (0.20")	1/4-19 BSPP
PH-M8-6R-TMS	8mm	68.6 (2.70")	24.7 (0.97")	21.9 (0.86")	20.0 (0.79")	19.0 (0.75")	25.4 (1.00")	25.4 (1.00")	6.0 (0.24")	3/8-19 BSPP
PH-M10-4R-TMS	10mm	69.6 (2.74")	25.7 (1.01")	22.9 (0.90")	21.0 (0.83")	22.0 (0.87")	25.4 (1.00")	25.4 (1.00")	6.0 (0.24")	1/4-19 BSPP
PH-M10-6R-TMS	10mm	69.6 (2.74")	25.7 (1.01")	22.9 (0.90")	21.0 (0.83")	22.0 (0.87")	25.4 (1.00")	25.4 (1.00")	8.0 (0.31")	3/8-19 BSPP
PH-M12-8R-TMS	12mm	77.7 (3.06")	26.7 (1.05")	23.1 (0.91")	22.0 (0.87")	25.0 (0.98")	28.6 (1.13")	28.6 (1.13")	8.0 (0.31")	1/2-14 BSPP
PH-M14-8R-TMS	14mm	79.7 (3.14")	26.7 (1.05")	23.3 (0.92")	22.0 (0.87")	28.0 (1.10")	30.2 (1.19")	31.8 (1.25")	10.0 (0.39")	1/2-14 BSPP
PH-M16-12R-TMS	16mm	84.6 (3.33")	29.7 (1.17")	25.9 (1.02")	25.0 (0.98")	32.0 (1.26")	34.9 (1.37")	34.9 (1.37")	12.0 (0.47")	3/4-14 BSPP
PH-M18-12R-TMS	18mm	90.6 (3.57")	35.6 (1.40")	31.6 (1.24")	29.5 (1.16")	36.0 (1.42")	38.1 (1.50")	38.1 (1.50")	14.0 (0.55")	3/4-14 BSPP
PH-M20-12R-TMS	20mm	90.6 (3.57")	35.6 (1.40")	31.0 (1.22")	29.5 (1.16")	36.0 (1.42")	38.1 (1.50")	38.1 (1.50")	14.0 (0.55")	3/4-14 BSPP
PH-M22-16R-TMS	22mm	97.6 (3.84")	37.6 (1.48")	32.7 (1.29")	31.0 (1.22")	43.0 (1.69")	44.5 (1.75")	44.5 (1.75")	16.0 (0.63")	1-11 BSPP
PH-M25-16R-TMS	25mm	100.3 (3.95")	40.3 (1.59")	34.8 (1.37")	33.5 (1.32")	50.0 (1.97")	50.8 (2.00")	47.6 (1.87")	18.0 (0.71")	1-11 BSPP

Dimensions for reference only, subject to change.

Phastite® Tube Connectors

TFS - R Termination Female Straight - BSPP

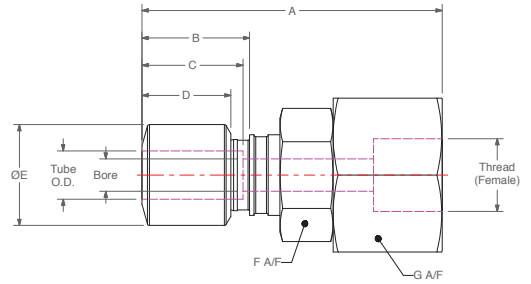
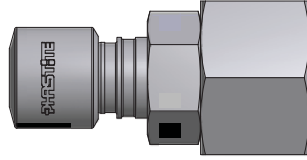

Imperial

Part No.	Tube O.D.	A	B	C	D	E	F	G	Bore	Thread
PH-4-4R-TFS	1/4"	70.1 (2.76")	23.7 (0.93")	20.9 (0.82")	19.0 (0.75")	17.0 (0.67")	20.6 (0.81")	28.6 (1.13")	4.0 (0.16")	1/4-19 BSPP
PH-6-4R-TFS	3/8"	72.6 (2.86")	25.7 (1.01")	22.9 (0.90")	21.0 (0.83")	22.0 (0.87")	25.4 (1.00")	25.4 (1.00")	6.0 (0.24")	1/4-19 BSPP
PH-6-6R-TFS	3/8"	74.1 (2.92")	25.7 (1.01")	22.9 (0.90")	21.0 (0.83")	22.0 (0.87")	25.4 (1.00")	25.4 (1.00")	6.0 (0.24")	3/8-19 BSPP
PH-8-8R-TFS	1/2"	78.6 (3.10")	26.7 (1.05")	23.6 (0.93")	22.0 (0.87")	25.0 (0.98")	28.6 (1.13")	38.1 (1.50")	8.0 (0.31")	1/2-14 BSPP
PH-10-12R-TFS	5/8"	83.1 (3.27")	29.7 (1.17")	25.9 (1.02")	25.0 (0.98")	32.0 (1.26")	34.9 (1.37")	38.1 (1.50")	12.0 (0.47")	3/4-14 BSPP
PH-12-12R-TFS	3/4"	89.1 (3.51")	35.6 (1.40")	31.2 (1.23")	29.5 (1.16")	36.0 (1.42")	38.1 (1.50")	38.1 (1.50")	14.0 (0.55")	3/4-14 BSPP
PH-14-16R-TFS	7/8"	93.6 (3.68")	37.6 (1.48")	32.4 (1.28")	31.0 (1.22")	43.0 (1.69")	44.5 (1.75")	47.6 (1.87")	16.0 (0.63")	1-11.5 BSPP
PH-16-16R-TFS	1"	96.3 (3.79")	40.3 (1.59")	34.8 (1.37")	33.5 (1.32")	50.0 (1.97")	50.8 (2.00")	47.6 (1.87")	18.0 (0.71")	1-11.5 BSPP

Variants suitable for use on Medium Pressure Tube i.e. 9/16" are available upon request.

TFS - R Termination Female Straight - BSPP

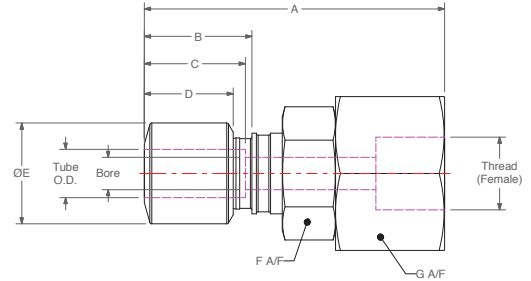
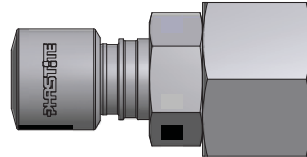

Metric

Part No.	Tube O.D.	A	B	C	D	E	F	G	Bore	Thread
PH-M6-4R-TFS	6mm	70.4 (2.77")	23.7 (0.93")	20.9 (0.82")	19.0 (0.75")	17.0 (0.67")	20.6 (0.81")	28.6 (1.13")	4.0 (0.16")	1/4-19 BSPP
PH-M8-4R-TFS	8mm	71.6 (2.82")	24.7 (0.97")	21.9 (0.86")	20.0 (0.79")	19.0 (0.75")	25.4 (1.00")	25.4 (1.00")	5.0 (0.20")	1/4-19 BSPP
PH-M8-6R-TFS	8mm	73.1 (2.88")	24.7 (0.97")	21.9 (0.86")	20.0 (0.79")	19.0 (0.75")	25.4 (1.00")	25.4 (1.00")	6.0 (0.24")	3/8-19 BSPP
PH-M10-4R-TFS	10mm	72.6 (2.86")	25.7 (1.01")	22.9 (0.90")	21.0 (0.83")	22.0 (0.87")	25.4 (1.00")	25.4 (1.00")	6.0 (0.24")	1/4-19 BSPP
PH-M10-6R-TFS	10mm	74.1 (2.92")	25.7 (1.01")	22.9 (0.90")	21.0 (0.83")	22.0 (0.87")	25.4 (1.00")	25.4 (1.00")	8.0 (0.31")	3/8-19 BSPP
PH-M12-8R-TFS	12mm	78.7 (3.10")	26.7 (1.05")	23.1 (0.91")	22.0 (0.87")	25.0 (0.98")	28.6 (1.13")	38.1 (1.50")	8.0 (0.31")	1/2-14 BSPP
PH-M14-8R-TFS	14mm	78.7 (3.10")	26.7 (1.05")	23.3 (0.92")	22.0 (0.87")	28.0 (1.10")	30.2 (1.19")	38.1 (1.50")	10.0 (0.39")	1/2-14 BSPP
PH-M16-12R-TFS	16mm	83.1 (3.27")	29.7 (1.17")	25.9 (1.02")	25.0 (0.98")	32.0 (1.26")	34.9 (1.37")	38.1 (1.50")	12.0 (0.47")	3/4-14 BSPP
PH-M18-12R-TFS	18mm	89.1 (3.51")	35.6 (1.40")	31.6 (1.24")	29.5 (1.16")	36.0 (1.42")	38.1 (1.50")	38.1 (1.50")	14.0 (0.55")	3/4-14 BSPP
PH-M20-12R-TFS	20mm	89.1 (3.51")	35.6 (1.40")	31.0 (1.22")	29.5 (1.16")	36.0 (1.42")	38.1 (1.50")	38.1 (1.50")	14.0 (0.55")	3/4-14 BSPP
PH-M22-16R-TFS	22mm	93.6 (3.69")	37.6 (1.48")	32.7 (1.29")	31.0 (1.22")	43.0 (1.69")	44.5 (1.75")	47.6 (1.87")	16.0 (0.63")	1-11 BSPP
PH-M25-16R-TFS	25mm	96.3 (3.79")	40.3 (1.59")	34.8 (1.37")	33.5 (1.32")	50.0 (1.97")	50.8 (2.00")	47.6 (1.87")	18.0 (0.71")	1-11 BSPP

Dimensions for reference only, subject to change.

Phastite® Tube Connectors

TXAS Termination Male Straight - 20,000 PSI* Medium Pressure

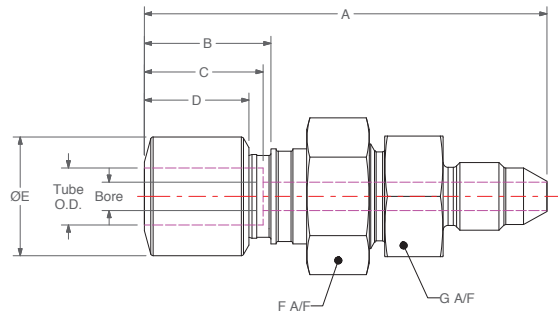
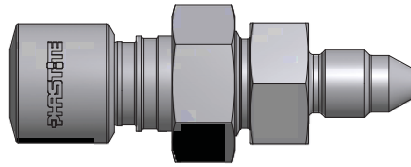

Imperial

Part No.	Tube O.D.	A	B	C	D	E	F	G	Bore	MP size
PH-4-4-TXAS	1/4"	69.9 (2.75")	23.7 (0.93")	20.9 (0.82")	19.0 (0.75")	17.0 (0.67")	20.6 (0.81")	19.0 (0.75")	4.0 (0.16")	1/4"
PH-6-6-TXAS	3/8"	77.2 (3.04")	25.7 (1.01")	22.9 (0.90")	21.0 (0.83")	22.0 (0.87")	25.4 (1.00")	25.4 (1.00")	6.0 (0.24")	3/8"
PH-8-9-TXAS	1/2"	84.0 (3.31")	26.7 (1.05")	23.6 (0.93")	22.0 (0.87")	25.0 (0.98")	28.6 (1.13")	28.6 (1.13")	8.0 (0.31")	9/16"
PH-10-9-TXAS	5/8"	91.0 (3.58")	29.7 (1.17")	25.9 (1.02")	25.0 (0.98")	32.0 (1.26")	34.9 (1.37")	34.9 (1.37")	12.0 (0.47")	9/16"
PH-12-12-TXAS	3/4"	102.1 (4.02")	35.6 (1.40")	31.2 (1.23")	29.5 (1.16")	36.0 (1.42")	38.1 (1.50")	38.1 (1.50")	14.0 (0.55")	3/4"
PH-14-16-TXAS	7/8"	118.2 (4.65")	37.6 (1.48")	32.4 (1.28")	31.0 (1.22")	43.0 (1.69")	44.5 (1.75")	44.5 (1.75")	16.0 (0.63")	1"
PH-16-16-TXAS	1"	120.9 (4.76")	40.3 (1.59")	34.8 (1.37")	33.5 (1.32")	50.0 (1.97")	50.8 (2.00")	47.6 (1.87")	18.0 (0.71")	1"

Variants suitable for use on Medium Pressure Tube i.e. 9/16" are available upon request.

TXAS Termination Male Straight - 20,000 PSI* Medium Pressure

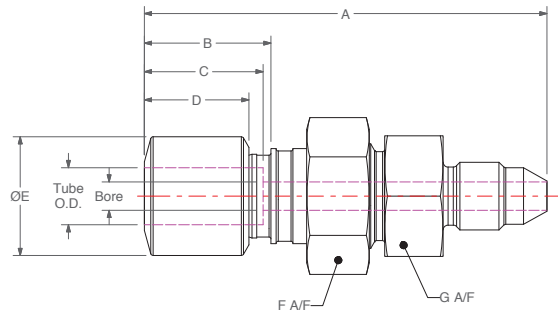
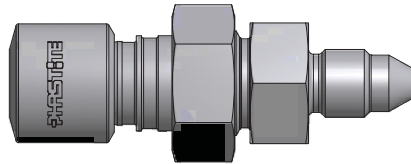

Imperial

Part No.	Tube O.D.	A	B	C	D	E	F	G	Bore	MP size
PH-M6-4-TXAS	6mm	70.2 (2.76")	23.7 (0.93")	20.9 (0.82")	19.0 (0.75")	17.0 (0.67")	20.6 (0.81")	19.0 (0.75")	4.0 (0.16")	1/4"
PH-M8-6-TXAS	8mm	76.2 (3.00")	24.7 (0.97")	21.9 (0.86")	20.0 (0.79")	19.0 (0.75")	25.4 (1.00")	25.4 (1.00")	6.0 (0.24")	3/8"
PH-M10-6-TXAS	10mm	77.2 (3.04")	25.7 (1.01")	22.9 (0.90")	21.0 (0.83")	22.0 (0.87")	25.4 (1.00")	25.4 (1.00")	8.0 (0.31")	3/8"
PH-M12-9-TXAS	12mm	84.1 (3.31")	26.7 (1.05")	23.1 (0.91")	22.0 (0.87")	25.0 (0.98")	28.6 (1.13")	28.6 (1.13")	8.0 (0.31")	9/16"
PH-M14-9-TXAS	14mm	86.0 (3.39")	26.7 (1.05")	23.3 (0.92")	22.0 (0.87")	28.0 (1.10")	30.2 (1.19")	31.8 (1.25")	10.0 (0.39")	9/16"
PH-M16-9-TXAS	16mm	91.0 (3.58")	29.7 (1.17")	25.9 (1.02")	25.0 (0.98")	32.0 (1.26")	34.9 (1.37")	34.9 (1.37")	12.0 (0.47")	9/16"
PH-M18-12-TXAS	18mm	102.0 (4.02")	35.6 (1.40")	31.6 (1.24")	29.5 (1.16")	36.0 (1.42")	38.1 (1.50")	38.1 (1.50")	14.0 (0.55")	3/4"
PH-M20-12-TXAS	20mm	102.0 (4.02")	35.6 (1.40")	31.0 (1.22")	29.5 (1.16")	36.0 (1.42")	38.1 (1.50")	38.1 (1.50")	14.0 (0.55")	3/4"
PH-M22-16-TXAS	22mm	118.2 (4.65")	37.6 (1.48")	32.7 (1.29")	31.0 (1.22")	43.0 (1.69")	44.5 (1.75")	44.5 (1.75")	16.0 (0.63")	1"
PH-M25-16-TXAS	25mm	120.9 (4.76")	40.3 (1.59")	34.8 (1.37")	33.5 (1.32")	50.0 (1.97")	50.8 (2.00")	47.6 (1.87")	18.0 (0.71")	1"

Dimensions for reference only, subject to change.

* Please note actual maximum working pressure is limited by Phastite connection/tube selection.

Phastite® Tube Connectors

Phastool

Phastite's unique design provides a secure leak tight grip on the tubing even with varying tube tolerances or surface finishes.

The connector make-up is completed by the use of either a hand held or bench mounted Phastool. The tools have built-in hydraulic cylinders, which are operated by means of a pump. The pump can be either air, electrically or manually operated.

For connections up to 1/2" and 12mm.

For the smaller sizes of Phastite® a light weight hand tool is available for ease of installation. The hand tool is supplied complete with a 2 meter hose and quick

connectors to suit a 3/8-14 NPT pump connection port. The unit is also supplied complete with all required jaw inserts for assembling all Phastite® connectors including shapes and termination product up to and including 1/2" and 12mm.

Hand Held Tool up to 1/2" and 12mm

Part No: PH-8-HANDTOOL

Mass: 4.8kg (10.6lb)

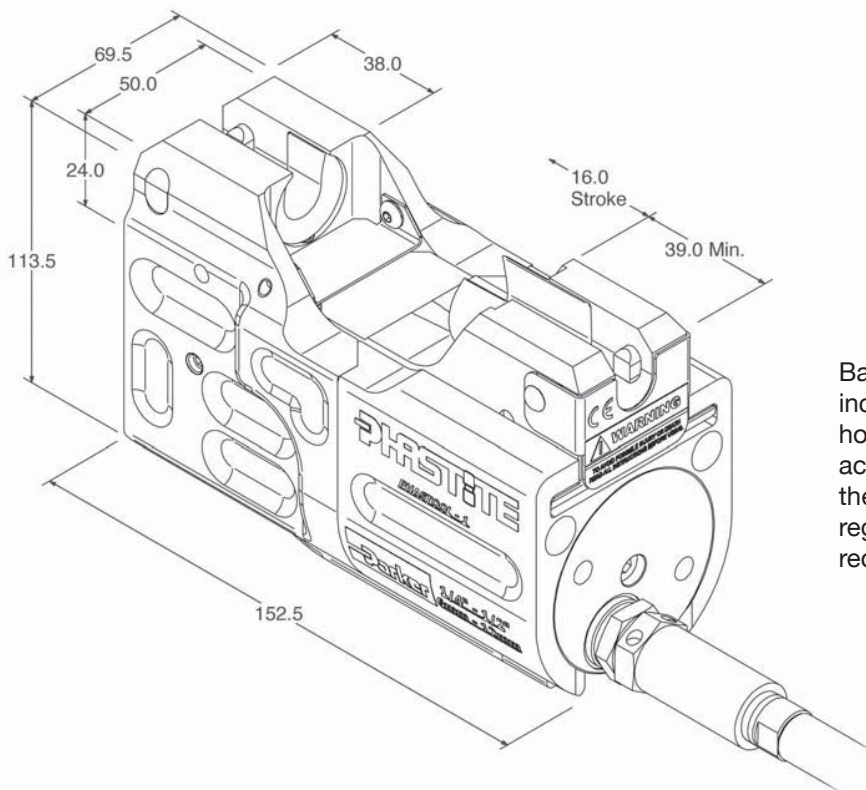

Basic dimensions of this tool are included for planning installations however for installation with limited access available it is advised to consult the factory for more information regarding jaw movement and access requirements.

Phastite® Tube Connectors

Tube Clearances

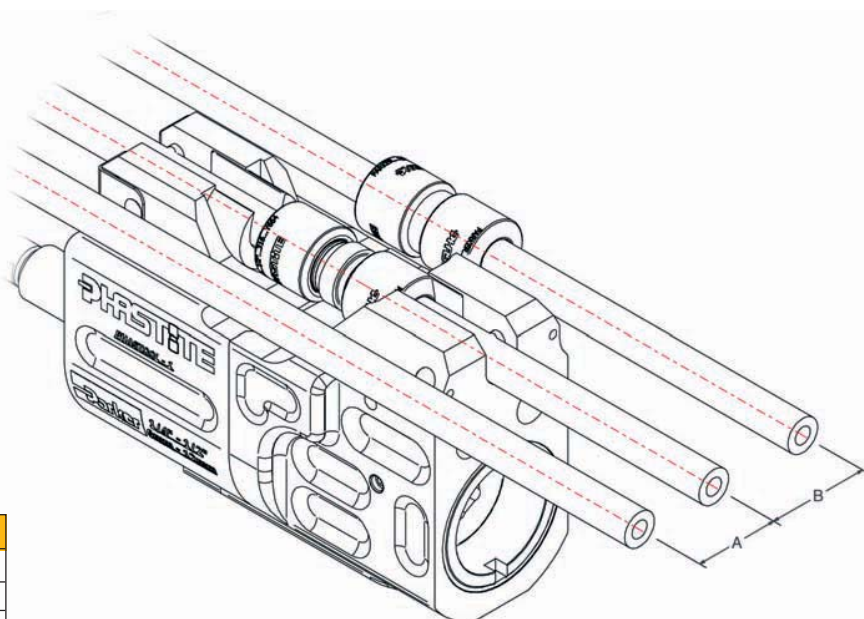

Tube Size	A	B
6mm - 1/4"	28.5	34.0
8mm	29.5	36.5
10mm - 3/8"	30.5	36.5
12mm - 1/2"	31.5	38.0

A - Minimum distance from centre line of fitting to centre line of tube run.

B - Minimum distance from centre line of fitting to centre line of tube run with additional Phastite® connectors close to joint.

Bench Mounting

The hand tool can also be supplied complete with an optional bench mountable tool holder.

Part No: PH-8-BENCHTOOL

Mass: 5.2kg (11.5lb)



The Bench Mount Bracket has four mounting holes as shown: Each hole is suited to take an M8 socket cap screw.

Phastite® Tube Connectors

For connections 1/2" to 1" and 12mm to 25mm.

For sizes of Phastite® a light weight bench tool is available for ease of installation. The hand tool is supplied complete with a 2 meter hose and quick connectors to suit a 3/8-14 NPT pump connections port. The unit is also supplied complete with all required jaw inserts for assembling all Phastite® connectors including shapes and termination product from 1/2" to 1" and 12mm to 25mm.

**Bench Tool 1/2" to 1" and
12mm to 25mm**

Part No: PH-16-BENCHTOOL

Mass: 20kg (44lb)



Basic dimensions of this tool are included for planning installations however for installation with limited access available it is advised to consult the factory for more information regarding jaw movement and access requirements.

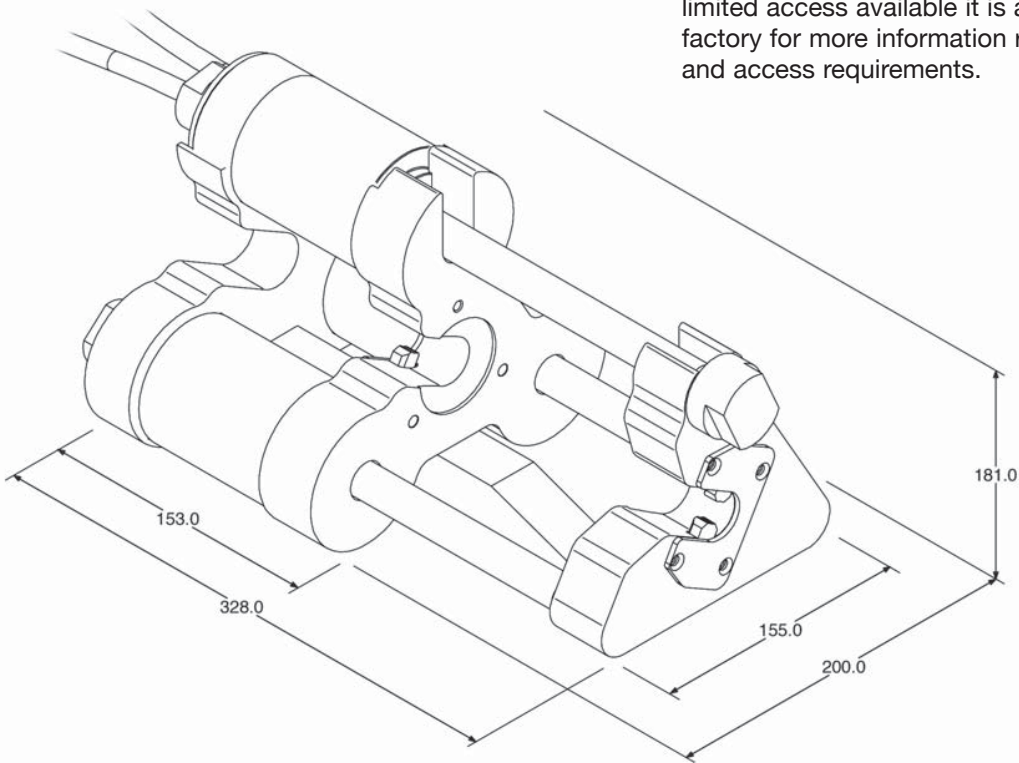

Tool jaw inserts

A complete set of jaw inserts are included with each tool kit (hand held or bench mounted) to enable assembly of all sizes and shapes of Phastite®. If additional inserts are required please use the information shown below.

Jaw inserts to suit tool PH-8-HANDTOOL and PH-8-BENCHTOOL.

Part No.	Phastite® Size		Comments
	Imperial	Metric	
PH-M6-INSERTS-T8	1/4"	6mm	Contains 4 inserts to assemble all permanent and termination product. (PH-SHAPE-INSERT-T8 will also be required for assembling shapes).
PH-M8-INSERTS-T8	N/A	8mm	
PH-M10-INSERTS-T8	3/8"	10mm	
PH-M12-INSERTS-T8	1/2"	12mm	
PH-SHAPE-INSERT-T8	up to 1/2"	up to 12mm	Use with the above inserts for shapes.



Jaw inserts to suit tool PH-16-BENCHTOOL.

Part No.	Phastite® Size		Comments
	Imperial	Metric	
PH-M12-INSERTS-T16	1/2"	12mm	Contains 4 inserts to assemble all permanent and termination product. (PH-SHAPE-INSERT-T16 will also be required for assembling shapes).
PH-M14-INSERTS-T16	N/A	14mm	
PH-M16-INSERTS-T16	5/8"	16mm	
PH-M20-INSERTS-T16	3/4"	18mm, 20mm	
PH-M22-INSERTS-T16	7/8"	22mm	Contains 2 inserts to assemble all permanent and termination product. (PH-SHAPE-INSERT-T16 will also be required for assembling shapes).
PH-M25-INSERTS-T16	1"	25mm	
PH-SHAPE-INSERT-T16	1/2" to 1"	12mm to 25mm	Use with the above inserts for shapes.



Inserts for assembling termination style Phastite® can be ordered by using the code **PH-M##-TERMININSERT-T\$**, where **##** represents the Phastite® size and **\$** represents the tool size. In the case of 8mm Phastite® Termination ends, the M10 insert should be used.

Phastite® Tube Connectors

Tube Markers

Adequate tube insertion is essential.

To achieve this, a range of Phastite® Tube Markers are available. The Phastite® Tube Marker generates two visible lines on to the outside diameter of the tube.

When inserting the tube into a Phastite® connector the two lines should not be visible. This ensures adequate tube insertion prior to assembly.

After assembly only one of the lines will be visible, ensuring that tube slippage has not occurred during assembly.

Two versions of these markers are available as follows:

Permanent Tube Marker

This style of tube marker generates two permanent lines onto the tube. These lines can be used for initial inspection during assembly and for future inspection. These tube markers generate the marks by means of a metallic ball bearing being rotated against the tube.



Temporary Tube Marker

This style of tube marker acts as a pen guide. This allows the user to mark the tube using a pen. These lines can be used for initial inspection during assembly however they cannot be used for future inspection.

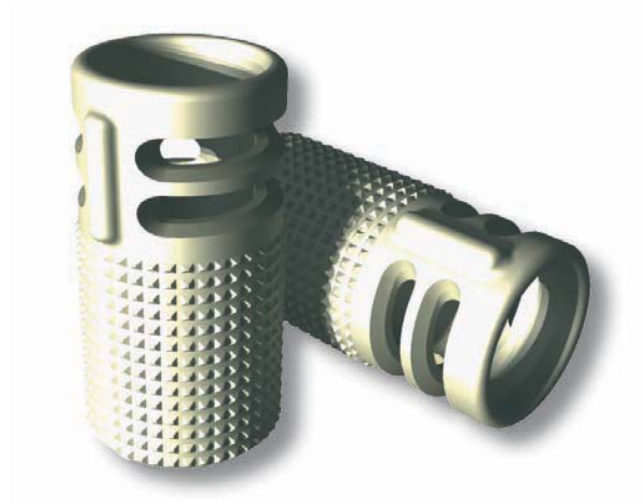

Tube Marker Part Numbers

Tube marker part numbers are as follows:

PH-TUBEMARKER-*-#.

Where * must be replaced by 'P' for the permanent tube marker and 'T' for the temporary pen tube marker.

And # must be replaced with the tube size as follows:
For imperial sizes add the size in 1/16" of an inch increments i.e. 4 = 1/4" and 10 = 5/8".
For metric sizes add 'M' followed by the size i.e. M6 = 6mm and M18 = 18mm.

Pumps

Lightweight hand pump

Part number: PH HAND PUMP. 1

- Lightweight and compact.
- Two speed operation reducing the number of handle strokes required.
- Lower handle effort required to operate.
- Handle lock and lightweight construction for easy carrying.
- Internal pressure relief valve for overload protection.
- Non-conductive fibre glass handle for operator safety.



Electric pump

Part number: PH ELECTRIC PUMP. 1

- Lightweight and compact design.
- Large easy carry handle.
- Two speed operation reduces cycle time.
- 230 VAC 50/60 cycle motor (For 115 Volt applications, replace model number '1' suffix with '2').
- High strength moulded cover, with built in handle, protects the motor from contamination and damage.

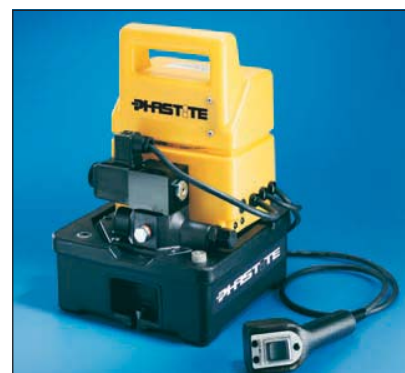

Air pump

Part number: PH AIR PUMP. 1

- Low air consumption and operating costs.
- Internal pressure relief valve provides override protection.
- Quiet operation.
- Operating pressure is 60 to 120 psi (4.1 to 8.3 bar).
- High efficiency cast aluminium air motor.
- ATEX approved (requires external earth connection).



Phastite® Tube Connectors

How to Order

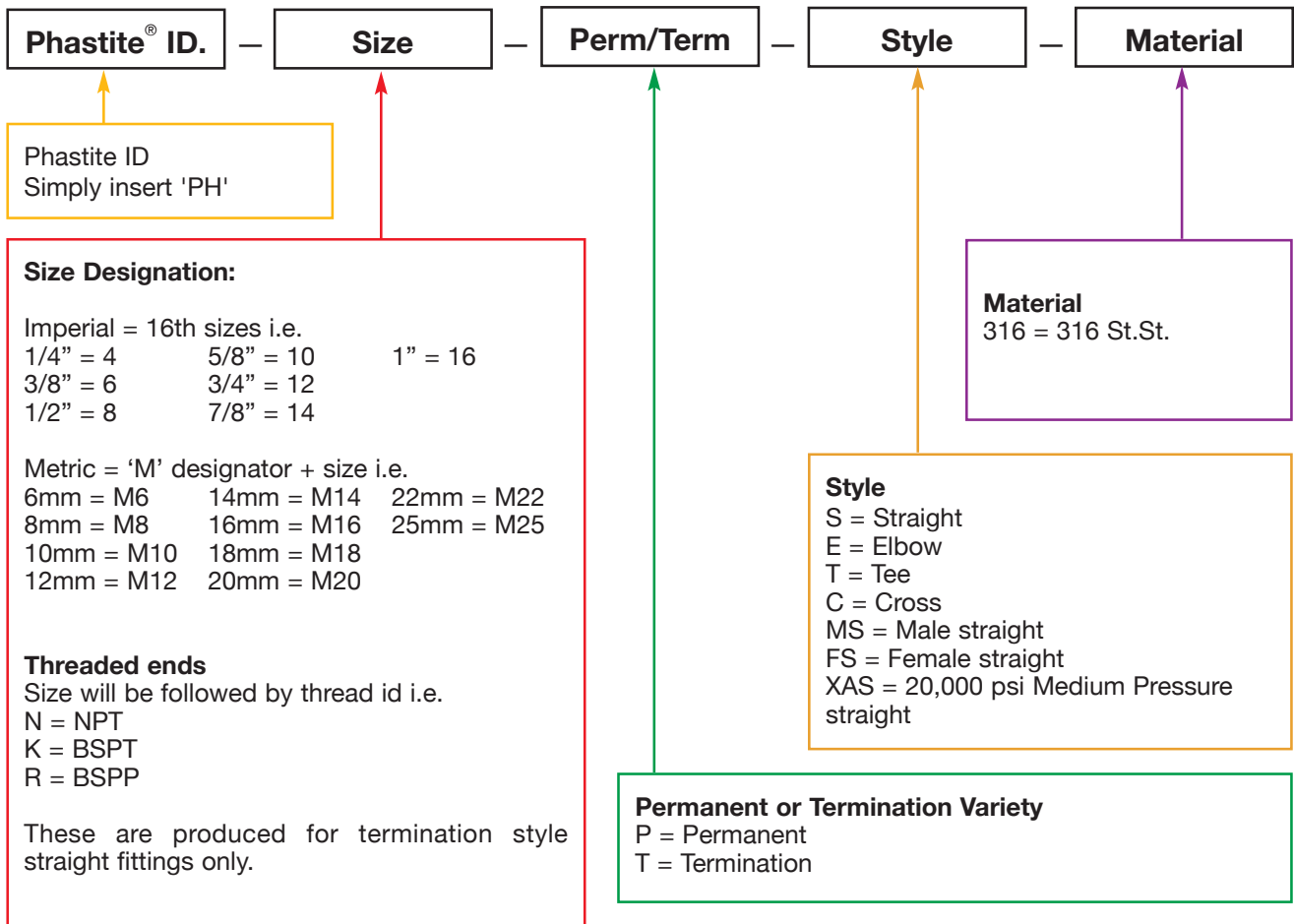

Examples

1/2" Phastite® Straight, Perm, 316

PH-8-PS-316

1/2" Phastite® termination to 1/2 NPT (Male), Straight, 316

PH-8-8N-TMS-316

6mm Phastite® Tee, Perm, 316

PH-M6-PT-316

Tube selection and pressure ratings for ASTM A-269 tubing in 304/316 stainless steel used with Phastite® connectors

General selection criteria.

Phastite® tube connectors have been designed to work in a wide variety of applications that demand the utmost in product performance. Although Phastite® connectors have been engineered and manufactured to consistently provide this level of reliability, no system integrity is complete without considering the critical link, tubing.

This guide is intended to assist the designer to properly select and order the correct quality tubing. **Correct tube selection and installation are key ingredients in building leak-free reliable tubing systems.** The most important consideration in the selection of suitable tubing for any application is the compatibility of the tubing material with the media to be contained. In addition tubing compatibility with the connector should be considered, as dissimilar materials in contact may be susceptible to galvanic corrosion. The differential in material hardness may also affect their ability to correctly hold onto and seal the tubing.

Pressure ratings for combinations of tube and connector.

The pressure rating of a Phastite® connection assembly is that of the tube with the highest-pressure rating to which it can be attached and is presented in

Tables 1 through 4 of this guide. The pressure rating of the tube has been calculated in accordance with ANSI B31.3, Chemical Plant and Petroleum Refinery Piping standard, assuming maximum diameter, minimum wall thickness and minimum Ultimate Tensile Strength (UTS).

In the case of an all tube-ended connector, such as a union tee, the properly selected tubing is the limiting factor in the system. A termination connector may, however, combine a Phastite® connector end with another end of different form, such as male or female pipe thread. Pressure ratings for other ends are determined in accordance with applicable standards and may, in fact, be lower than the rating for the Phastite® tube connector end.

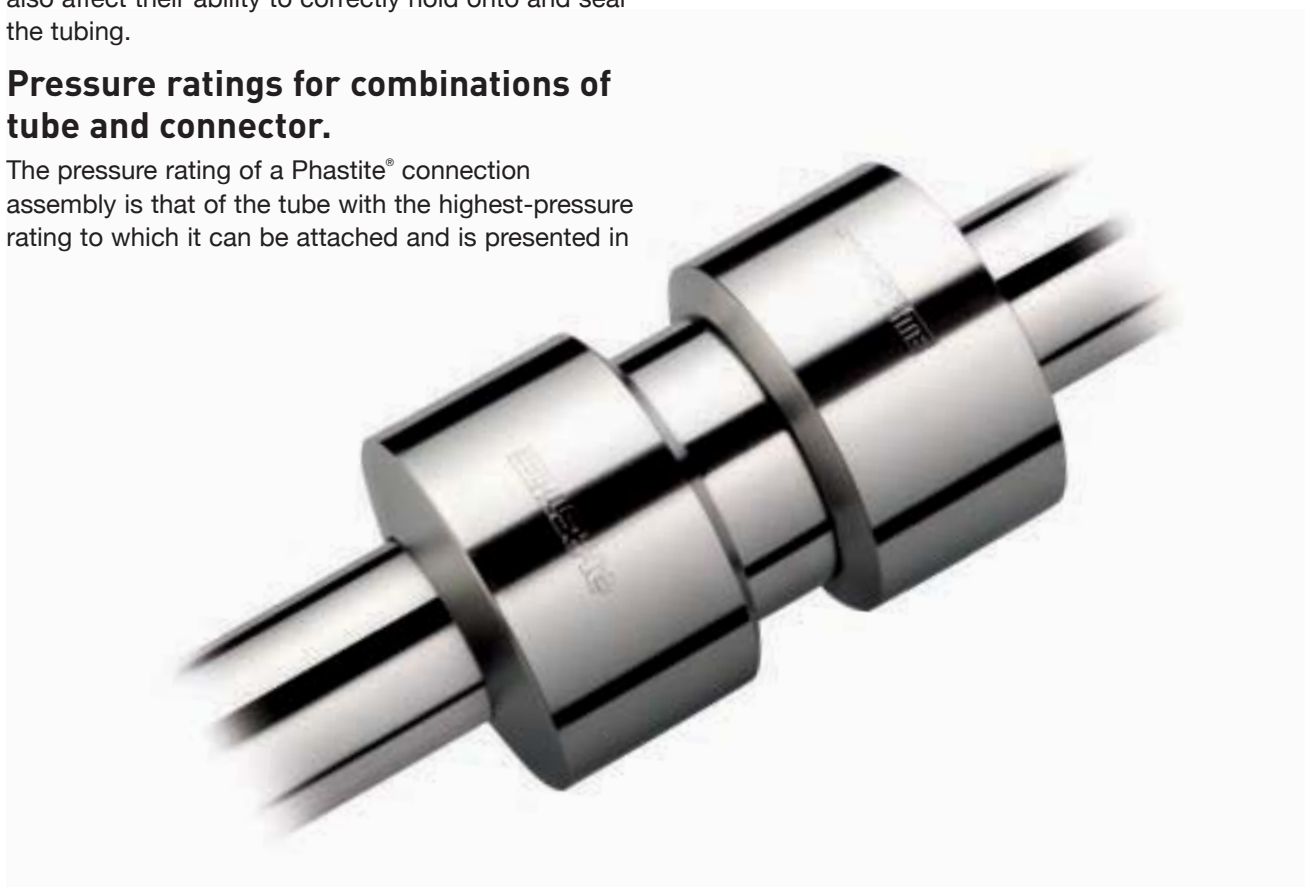

Phastite® Tube Connectors

Pressure rating and wall thickness of tubes.

Tables 1 to 2 present the pressure ratings for type 304 or 316 stainless steel seamless tubes for temperatures up to 93°C (200°F). These tables also show the minimum and maximum wall thickness of tubes that shall be used within the scope of the Parker Phastite® design for each size of tube connector.

If a user chooses a tube wall thickness outside those recommended in tables 1 to 2, the user should first consult the technical department of Parker Instrumentation Products Division.

Derating factors for Welded and drawn tubing.

For welded and drawn tubing, a derating factor shall be applied for weld integrity. For double – welded tubing pressure ratings in tables 1 though 2 by a factor of 0.85 and for single – welded tubing multiply ratings in the tables by 0.80.

Derivation of pressure ratings.

The working pressure ratings for stainless steel tubing shall be derived from stress values and methodologies listed in ASME B31.3, Chemical Plant and Petroleum Refinery Piping standard.

Table 1

Tube O.D.	Phastite Maximum Product Rating - PSI (bar) ^v	Wall Thickness Maximum Tube Assembly Rating - PSI (bar) [*]												
		0.035" ⁺	0.049"	0.065"	0.083"	0.095"	0.109"	0.120"	0.125"	0.156"	0.188"			
1/4"	20,000 (1379)	5,100 (352)	7,500 (517)	10,300 (710)	13,300 (917)									
3/8"	15,500 (1069)	3,300 (228)	4,800 (331)	6,600 (455)	8,600 (593)	10,000 (689)								
1/2"	15,000 (1034)	2,600 (179)	3,700 (255)	5,100 (352)	6,700 (462)	7,800 (538)	9,100 (627)	10,100 (696)	10,500 (724)					
5/8"	12,500 (862)		2,950 (203)	4,000 (276)	5,200 (359)	6,050 (417)	7,100 (490)	7,900 (545)	8,300 (572)					
3/4"	10,000 (689)		2,400 (165)	3,300 (228)	4,250 (293)	4,950 (341)	5,800 (400)	6,450 (445)	6,750 (465)	8,650 (596)				
7/8"	8,750 (603)		2,050 (141)	2,800 (193)	3,600 (248)	4,200 (290)	4,850 (334)	5,400 (372)	5,650 (390)	7,300 (503)				
1"	8,750 (603)			2,400 (165)	3,150 (217)	3,650 (252)	4,200 (290)	4,700 (324)	4,900 (338)	6,250 (431)	7,750 (534)			

Table 2

Tube O.D.	Phastite Maximum Product Rating - PSI (bar) ^v	Wall Thickness Maximum Tube Assembly Rating - PSI (bar) [*]												
		0.8mm ⁺	1.0mm	1.2mm	1.5mm	1.8mm	2.0mm	2.2mm	2.5mm	2.8mm	3.0mm	3.5mm	4.0mm	4.5mm
6mm	20,000 (1379)	4,800 (331)	6,200 (427)	7,600 (524)	9,800 (676)	11,900 (820)	13,300 (917)							
8mm	17,000 (1172)		4,500 (310)	5,500 (379)	7,200 (496)	8,800 (607)	9,900 (683)	10,900 (752)						
10mm	15,500 (1069)		3,600 (248)	4,300 (296)	5,600 (386)	6,900 (476)	7,700 (531)	8,600 (593)	9,900 (683)					
12mm	15,000 (1034)		2,900 (200)	3,600 (248)	4,600 (317)	5,600 (386)	6,300 (434)	7,000 (483)	8,100 (558)	9,200 (634)	9,900 (683)			
14mm	12,500 (862)		2,650 (183)	3,250 (224)	4,100 (283)	5,050 (348)	5,650 (390)	6,300 (434)	7,300 (503)	8,250 (569)	8,900 (614)			
16mm	10,000 (689)		2,300 (159)	2,800 (193)	3,550 (245)	4,350 (300)	4,900 (338)	5,400 (372)	6,250 (431)	7,150 (493)	7,700 (531)	9,150 (631)		
18mm	10,000 (689)				3,150 (217)	3,850 (265)	4,300 (296)	4,750 (328)	5,500 (379)	6,250 (431)	6,750 (465)	8,050 (555)		
20mm	10,000 (689)				2,800 (193)	3,400 (234)	3,800 (262)	4,250 (293)	4,900 (338)	5,550 (383)	6,000 (414)	7,150 (493)	8,300 (572)	
22mm	8,750 (603)				2,550 (176)	3,100 (214)	3,450 (238)	3,850 (265)	4,400 (303)	5,000 (345)	5,400 (372)	6,400 (441)	7,450 (514)	
25mm	8,750 (603)				2,200 (152)	2,700 (186)	3,000 (207)	3,350 (231)	3,800 (262)	4,350 (300)	4,700 (324)	5,550 (383)	6,450 (445)	7,400 (510)

^{*} Calculated Pressure Rating to ASME B31.3
Based on ASTM A269 - 316

^v Pressure Rating verified by test based on 4:1 FOS.
Utilising ASTM A269 - 316 tube with a typical UTS of 600 Mpa and typical hardness of Rb 80 - 90.

⁺ 0.035" and 0.8mm wall thickness tubes whilst suitable, are not recommended for prolonged useage in applications where heavy vibration and combined pulsation are present.

Note on selection.

The pressure rating information presented here, is intended as a useful guide to demonstrate the performance potential of the Phastite® fitting when properly installed according to Parker recommended practices and to assist the user in the proper selection of tube and fitting for a particular application. Every effort is made to ensure this information is clearly presented but it is the responsibility of the user and the system designer to ensure the appropriate selection and specification of tube and fitting and that the specified assembly meets the requirements of the system or application.

Pressure rating at elevated temperatures

Factors used to determine tubing pressure ratings at elevated temperatures:

Table 3

°C	°F	304 St. St.	316 St. St.
93	200	1.00	1.00
204	400	0.93	0.96
315	600	0.82	0.85
426	800	0.76	0.79
537	1000	0.69	0.76

To determine allowable pressure at elevated temperatures, multiply the allowable working pressure from tables 1 to 2 by the factor shown in table 3 above.

Example: 12mm x 1.5mm wall 316 stainless steel tubing has a working pressure of 317 bar @ room temperature. If the system were to operate at 426°C, a factor of 79% or 0.79 would apply (see table 3) and the “at temperature” system pressure would therefore be $317 \times 0.79 = 250$ bar.

These factors are based on ASME B31.3 derating factors for ASTM A269 tubing. They are derived from table A-1, basic allowable stresses in metals.

Tubing ordering suggestions.

Stainless steel tubing for use with Phastite connectors should be ordered to insure adequate quality for good performance. Each request for tubing should specify the material, nominal outside diameter, and wall thickness. Ordering to the correct ASTM specifications ensures that the tubing will be dimensionally, physically and chemically within the strict limits as laid down in the standard. In addition to this, the tubing should be ordered as, free from scratches and imperfections and suitable for bending or flaring. The tubing should be fully annealed, 80Rb or less (Rb 90 absolute maximum) and delivered in a proper manner to preserve the product quality.

The following grades and standards can be used successfully with Phastite® 316 stainless steel fittings:

Materials:

304, 316 or 316L

ASTM tubing spec.

ASTM A-269, A-249, A-213 or A-632

Phastite® Tube Connectors

Heat Code Traceability (HCT)

HCT refers to the fact that a specific part can be traced back to the original mill heat of metal from which it was made. Beginning with the original melt, a package of documents is created which completely describes the metal in physical and chemical terms. The end result is that a number, which is permanently stamped to the part, refers back to the document package.

HCT offers these advantages:

- Raw materials for manufacture must meet code requirements. This can be verified through documentation so that the customer is certain that what is ordered is received.
- HCT provides a record of chemical analysis with the raw material.
- HCT relieves the user of Parker instrumentation fittings of any doubts. It acts as an assurance for today and for tomorrow.

The material used in Phastite® connectors is ASTM A276 Type 316.

The American Society of Mechanical Engineers (ASME) Boiler and Vessel Code, Section III, latest issue, entitled Rules for Construction of Nuclear Power Plant Components, is the principal document covering this type of fitting in the nuclear field. ANSI Standard B.31.1.0, Power Piping, and ANSI Standard B.31.7, Nuclear Power Piping, are also important documents in the field.

In addition to the documentation of chemical and physical properties, great care is taken throughout the manufacture of Parker's connectors to ensure that potential stress corrosion will not be a problem in normal usage of the parts. Manufacturing processes avoid exposure of the parts to mercury or halogens, and control of thermal treatment avoids the condition known as continuous grain boundary carbide precipitation.



Phastite® Tube Connectors

Phastite® -ended Valve options

A wide variety of our valve products are available with Phastite® ends. Some examples are provided below. Please contact your local Parker representative for more details.



Phastite® Ball valve

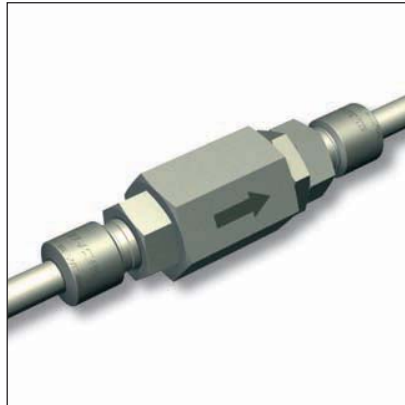

Phastite® Non-return valve



Phastite® Needle valve



Phastite® 20k psi Needle valve



Phastite® 20k psi Ball valve

Parker Worldwide

AE – UAE, Dubai

Tel: +971 4 8875600
parker.me@parker.com

AR – Argentina, Buenos Aires

Tel: +54 3327 44 4129

AT – Austria, Wiener Neustadt

Tel: +43 (0)2622 23501-0
parker.austria@parker.com

AT – Eastern Europe, Wiener Neustadt

Tel: +43 (0)2622 23501 970
parker.easteurope@parker.com

AU – Australia, Castle Hill

Tel: +61 (0)2-9634 7777

AZ – Azerbaijan, Baku

Tel: +994 50 2233 458
parker.azerbaijan@parker.com

BE/LX – Belgium, Nivelles

Tel: +32 (0)67 280 900
parker.belgium@parker.com

BR – Brazil, Cachoeirinha RS

Tel: +55 51 3470 9144

BY – Belarus, Minsk

Tel: +375 17 209 9399
parker.belarus@parker.com

CA – Canada, Milton, Ontario

Tel: +1 905 693 3000

CH – Switzerland, Etoy

Tel: +41 (0) 21 821 02 30
parker.switzerland@parker.com

CN – China, Shanghai

Tel: +86 21 5031 2525

CZ – Czech Republic, Klecany

Tel: +420 284 083 111
parker.czechrepublic@parker.com

DE – Germany, Kaarst

Tel: +49 (0)2131 4016 0
parker.germany@parker.com

DK – Denmark, Ballerup

Tel: +45 43 56 04 00
parker.denmark@parker.com

ES – Spain, Madrid

Tel: +34 902 33 00 01
parker.spain@parker.com

FI – Finland, Vantaa

Tel: +358 (0)20 753 2500
parker.finland@parker.com

FR – France, Contamine s/Arve

Tel: +33 (0)4 50 25 80 25
parker.france@parker.com

GR – Greece, Athens

Tel: +30 210 933 6450
parker.greece@parker.com

HK – Hong Kong

Tel: +852 2428 8008

HU – Hungary, Budapest

Tel: +36 1 220 4155
parker.hungary@parker.com

IE – Ireland, Dublin

Tel: +353 (0)1 466 6370
parker.ireland@parker.com

IN – India, Mumbai

Tel: +91 22 6513 7081-85

IT – Italy, Corsico (MI)

Tel: +39 02 45 19 21
parker.italy@parker.com

JP – Japan, Fujisawa

Tel: +(81) 4 6635 3050

KR – South Korea, Seoul

Tel: +82 2 559 0400

KZ – Kazakhstan, Almaty

Tel: +7 7272 505 800
parker.easteurope@parker.com

LV – Latvia, Riga

Tel: +371 6 745 2601
parker.latvia@parker.com

MX – Mexico, Apodaca

Tel: +52 81 8156 6000

MY – Malaysia, Subang Jaya

Tel: +60 3 5638 1476

NL – The Netherlands, Oldenzaal

Tel: +31 (0)541 585 000
parker.nl@parker.com

NO – Norway, Stavanger

Tel: +47 (0)51 826 300
parker.norway@parker.com

NZ – New Zealand, Mt Wellington

Tel: +64 9 574 1744

PL – Poland, Warsaw

Tel: +48 (0)22 573 24 00
parker.poland@parker.com

PT – Portugal, Leca da Palmeira

Tel: +351 22 999 7360
parker.portugal@parker.com

RO – Romania, Bucharest

Tel: +40 21 252 1382
parker.romania@parker.com

RU – Russia, Moscow

Tel: +7 495 645-2156
parker.russia@parker.com

SE – Sweden, Spånga

Tel: +46 (0)8 59 79 50 00
parker.sweden@parker.com

SG – Singapore,

Tel: +65 6887 6300

SK – Slovakia, Banská Bystrica

Tel: +421 484 162 252
parker.slovakia@parker.com

SL – Slovenia, Novo Mesto

Tel: +386 7 337 6650
parker.slovenia@parker.com

TH – Thailand, Bangkok

Tel: +662 717 8140

TR – Turkey, Istanbul

Tel: +90 216 4997081
parker.turkey@parker.com

TW – Taiwan, Taipei

Tel: +886 2 2298 8987

UA – Ukraine, Kiev

Tel: +380 44 494 2731
parker.ukraine@parker.com

UK – United Kingdom, Barnstaple

Tel: +44 (0)1271 313131
parker.uk@parker.com

US – USA, Cleveland

Tel: +1 216 896 3000

VE – Venezuela, Caracas

Tel: +58 212 238 5422

ZA – South Africa, Kempton Park

Tel: +27 (0)11 961 0700
parker.southafrica@parker.com

European Product Information Centre

Free phone: 00 800 27 27 5374

(from AT, BE, CH, CZ, DE, DK, EE, EI, ES, FI, FR, IT, NL, NO, PL, RU, SE, SK, UK, ZA)

© 2008 Parker Hannifin Corporation. All rights reserved

**Parker Hannifin Ltd**

Instrumentation Products Division
Riverside Road,
Pottington Business Park,
Barnstaple, Devon, EX31 1NP
United Kingdom
Tel.: +44 (0) 1271 313131
Fax: +44 (0) 1271 373636
www.parker.com/ipd

Parker Hannifin Corporation

Instrumentation Products Division
1005 A Cleaner Way
Huntsville, AL 35805
Tel: + 1 (256) 881-2040
Fax: + 1 (256) 881-5072
www.parker.com/ipdus

